

USER DRIVEN MANUAL*

Any feedback, changes, or advice we are glad to hear it. Please contact us at support@estateswing.com

—WARNING—

Read all instructions before beginning installation or use of this gate opener.

This operator exerts a high level of force.

Exercise caution at all times and stay clear of the system during operation.

Estate SWING

ESTATESWING.COM

E-SC 400 / 402 Classic Series

INSTRUCTION MANUAL

**Estate Swing's unique user driven manuals are constantly updated by installers and homeowners like yourself. We improve by hearing and applying your feedback.*

Estate Swing Summary of Functions

The Estate Swing is only to be used for vehicular swing gates in a Class I setting.

Class I: A vehicular gate opener (or system) intended for use in a home of one-to-four single family dwelling, or a garage or parking area associated therewith.

The Estate Swing automated system was designed and built for controlling vehicle access.
Do not use for any other purpose.

The external automation with an electro-mechanical non-reversing linear arm automates residential swing-leaf gates with leaves of up to 12' in length. It consists of an irreversible electro-mechanical operator with built in opening and closing limits and utilizes a worm screw system. The irreversible system ensures the gate is mechanical locked when the motor is not operating. A lock still needs to be installed if security or high winds are a concern. A manual release makes it possible to move the gate in the event of a power-cut or fault.

For Your Assistance

Keep this manual safely stored after installation

Serial Number _____

Date of Purchase _____

Place of Purchase _____

Have this information on hand while handling all service and warranty issues.

Table of Contents

The table of contents are listed to assist you locating a desired section. We do however strongly suggest studying every page of the instruction manual before attempting installation.

Section 1: Review of Specifications, Warnings, and Tools

Specifications of the Estate Swing and Components	1.1
Parts List	1.2
System Overview & Preliminary Checks	1.3
Tools Needed for Installation	1.4

Section 2: Installation

Manual Operation, Restoring Automation	2.1
IMPORTANT: Determining Setback	2.2
Installation of Operator	2.3-.6

Section 3: Wiring, Jumpers and Receiver

Control Box & Running Wires	3.1
Easy Wiring Under Driveway	3.2
Removing Terminal Strips for Wiring	3.3
Wiring Motors	3.4
Temporary Safety Jumpers & Dip Switch Settings	3.5
Power	3.6

Section 4: Start Up and Operation

Find Limit Position	4.1
First Run	4.2
Operating Parameters Customization	4.3

Section 5: Troubleshooting & Accessories

Troubleshooting	5.1-.3
Control Board Overview	5.4-.7
Accessories	5.8

Section 1:

Review of Specifications, Warnings, and Tools

Specifications

Model	Estate Swing E-SC 400 / 402
Power Supply	24V AC, 50VA
Backup Battery Voltage	24 V DC
Current (A)	3
Travel (in)	13
Cycles per hour	50% Duty Cycle / Aprox. 35
Operating Ambient Temp	-20 to 130 F
Protection Class	IP44
Gate leaf max length (ft.)	Up to 12
Gate leaf max weight (lbs.)	Up to 600
Operator Type	Screw Drive
Operator Weight	14 lbs.

Gate Weight / Length Ratio	6'	8'	10'
100 lbs	X* X	X* X	X*
200 lbs	X* X	X*	X*
300 lbs	X* X	X*	
400 lbs	X*		

X = Standard Arm
X* = Optional Arm

The above chart represents the maximum weight and length combinations that this gate opener can handle. The lengths and weights are either for a single gate or for a single leaf of a dual gate.

Estate Swing Parts List

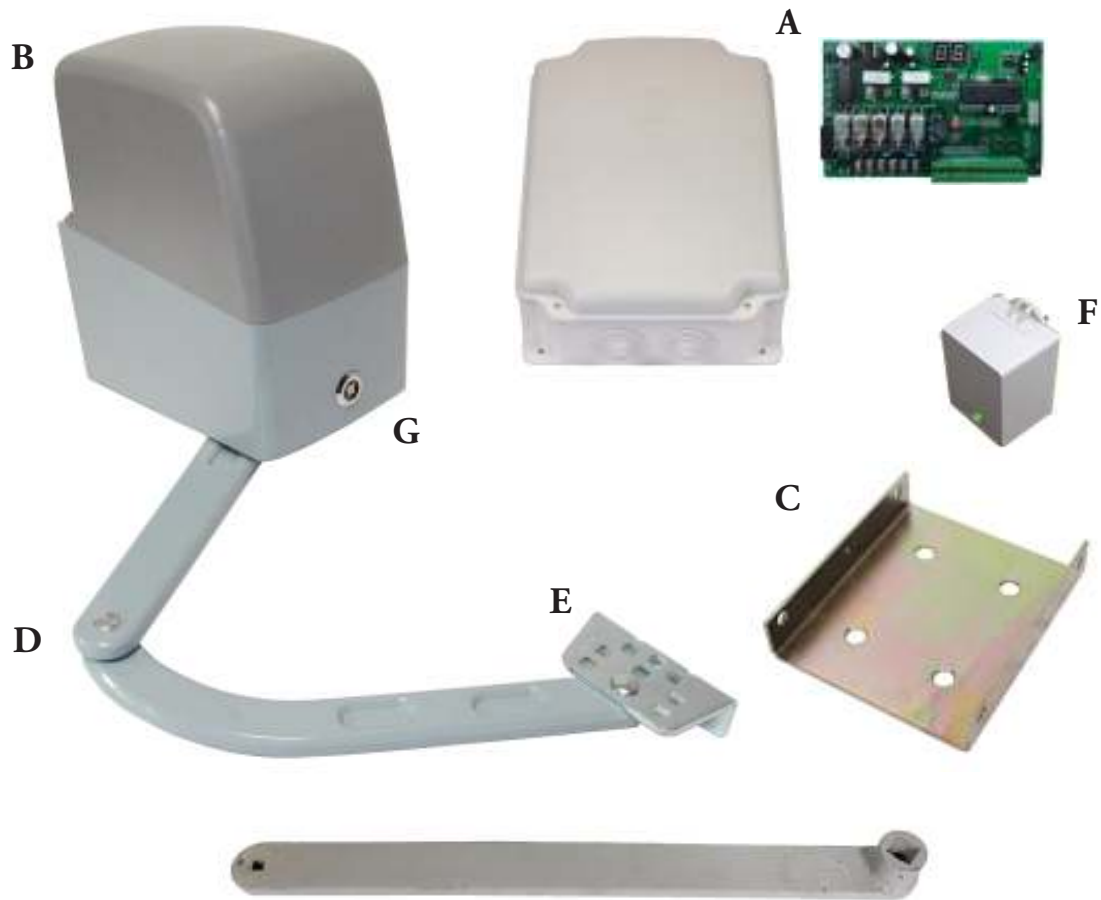

*Optional articulating arm

Master or Single Operator

- A. Control Box and Control Board
- B. Operator Motor
- C. Wall Mounting Bracket
- D. Articulating Arms
- E. Gate Bracket
- F. Transformer
- G. Manual Release

Not Shown:

- Remote / Transmitter
- Mount Bolts
- Receiver
- Motor Bolts

Slave Operator (If applicable)

- A. N/A
- B. Operator Motor
- C. Wall Mounting Bracket
- D. Articulating Arms
- E. Gate Bracket
- F. N/A
- G. Manual Release

Not Shown:

- Motor Bolts
- Mount Bolts

Standard System Overview and Safety Zones

The system displayed below is a recommended standard system. Other approved accessories can be installed. Photo sensors and a flashing light indicating gate movement is recommended for safety purposes.

1,2 Estate Swing Operator • 3 Photocells (not included) • 4 Control Board • 5 N/A • 6 Push button opening device (not included) • 7 Receiver extension (not included) • 8 24VDC flashing lamp (not included) • 9 Positive Stop (not included) • 10 AC Transformer

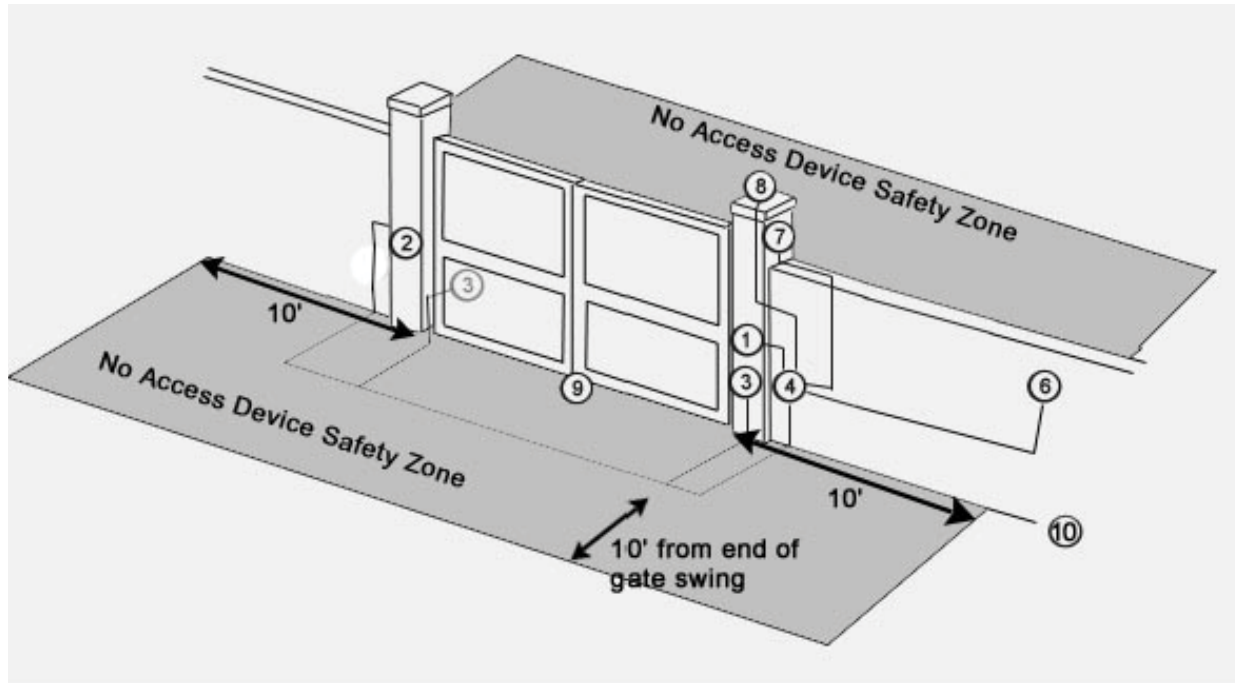

Notes: 1) When laying electrical cables, use appropriate rigid and/or flexible tube.
2) Do not run any wires in the same conduit as 110 AC power that may be in the area. This will cause danger of electrocution.

IMPORTANT: Preliminary Checks

To ensure safety and an efficiently operating automated system, make sure the following conditions are observed.

- The gate and post must be suitable for being automated. Check that the structure is sufficiently strong and rigid, and its dimensions and weights conform to those indicated on page 1.
- Make sure the gates move smoothly without any irregular friction during entire travel.
- Make sure the hinges are in good condition. Ball bearing hinges are ideal for gates weighing over 200 lbs. or over 10' in length.
- Make sure the gate is plumb and level.
- The fence post must be secured in the ground with concrete. This will prevent alteration of alignments and leveling during installation and during cycles.

Tools Needed for Installation

- Power Drill
- Crescent Wrench
- Flat Head Screwdriver
- Hacksaw/Sawzall
- Phillips Head Screwdriver
- C-Ring Pliers
- Tape Measure
- Level
- Wire Strippers
- C-clamps
- 3/8", 1/4", 5/16" Drill Bits



Protect all ingoing and outgoing wires with a surge suppressor.
Consult your local dealer for more information.

Other items that may be needed prior to commencing installation. **BOLDED** items are necessary to all applications.

- Start and stop post, bracket or gate stop. Although the Estate Swing E-SC 400 features soft start/stop and is used with limit switches, having stops in place ensure a more secure end position.
- **16 gauge, 2 conductor stranded direct burial low voltage wire will be required to run power to your operator.** Length is determined by distance between transformer power supply and the control box.
- A voltage meter and digital camera may be necessary to run diagnostic checks.
- **4 - 3/8" Red Heads, Lag Screws and Shields, or another brand column mounting 3/8" bolt and anchor will be needed to connect the Base Plate to the column.**
- **2 - 5/16" Hex Bolts will be needed to connect the Gate Mounting Bracket to the gate.** Length will be determined by the gate horizontal member thickness.
- If your transformer is going to be plugged into an outdoor outlet you will need to weatherproof that outlet and transformer. **Electrical boxes or plug covers** can be obtained from a local hardware store to accommodate both the plug and transformer.
- Hardware to attach the control box to a post or fence.

Section 2:

Manual Operation & Installation

Manual Operation

Manual operation mode will disengage the gears from the motor and allow the gates to be open and closed manually. It is also useful for emergency situations where as using the motor is not an option for operation the gates.

Fit the supplied release key in the hole and turn it clockwise until the key stops and does not spring back to its original position.



Restoring Standard Operation

To avoid an involuntary pulse activating the gates during the maneuver, switch off all power before re-locking the operator.

Fit the supplied release key in the hole and turn it until the key springs back to its original position.

IMPORTANT: Determining Correct Setback

The gate opener is designed to be on the inside of the property and pull the gate in towards the property.

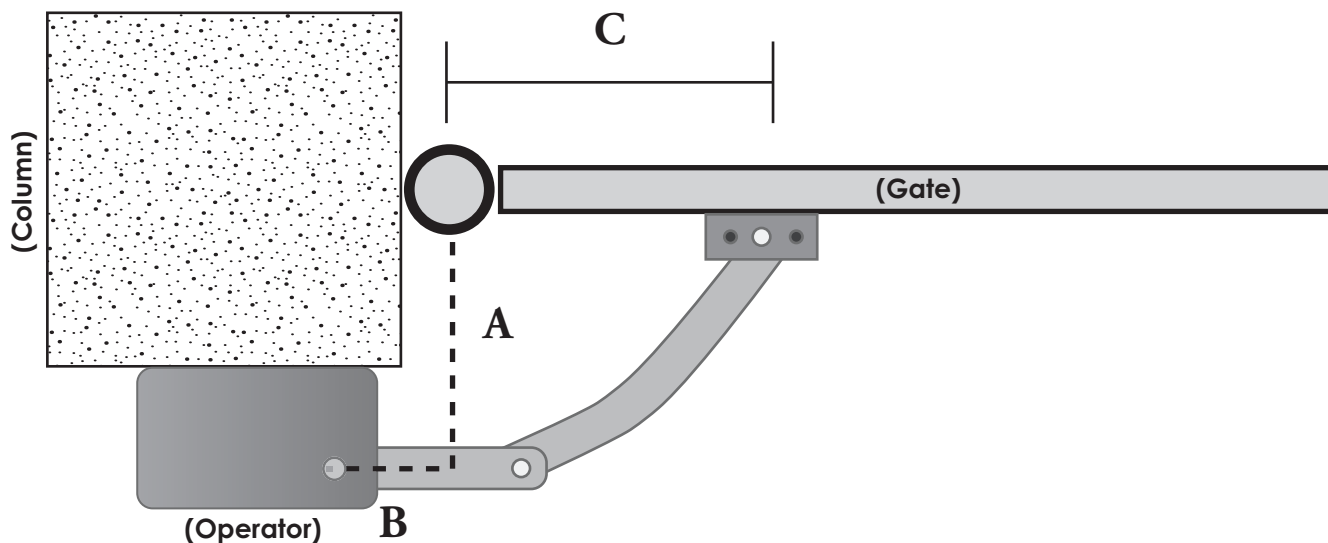

A = distance from center of hinge to rear of column.

B = distance from hinge to perpendicular intersection of the center of the motor.

C = distance from hinge to center of gate mount bracket.

A	B	C	Bracket
13" - 15" (6" - 8" column*)	5"	22"	Large
11" - 13" (4" - 6" column*)	3"	16"	Small

The **A** measurement shown above shows the ranged measurements for the setback. The measurements for **B** and **C**, however, are constant.

Installation of Operator

The operator base plate and articulated arm are designed either for right-handed or left-handed installation. There is no pre-determined designation.

1) On a piece of cardboard, create a template. From a corner of the cardboard, measure your **A** measurement. Cut at that point and back to the corner.

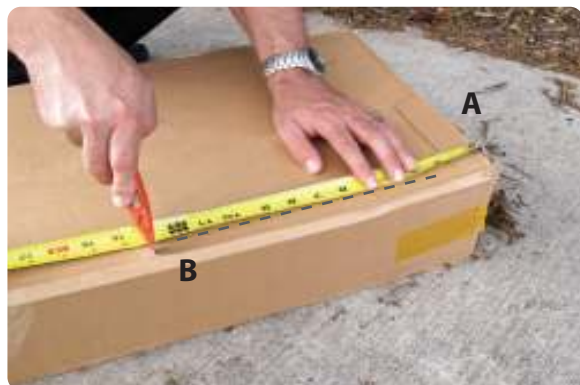

2) On the same piece of cardboard, 90 degrees from the first measurement, mark and cut your **B** measurement.

3) Use the template to find the correct setback for your motor. The measurement goes from the hinge of the gate to the drive shaft of the motor.



4) Check to make sure you have clearance for your motor from the face of the column. You must have at minimum of 7 inches from the face of the column to the drive shaft of the motor.

Installation of Operator

5) Find your horizontal position on the column for your motor bracket. The motor bracket should be centered at the end of the B measurement. Using a carpenter's pencil, make a vertical mark on the two sides of the bracket.



6) Find your vertical position of the column for your motor bracket. Identify the horizontal bar on the gate you are going to attach the motor arm to. The top of the horizontal bar on the gate being used for mounting should be level with the bottom of the motor bracket.

TIP: Take a level and rest one end of the level on the top of the lip of the bottom of the bracket. Place the other end of the level resting on the top of the gate's horizontal bracket.

7) Place the bracket in the final position that is matched up horizontally and vertically to the above two steps. If purchasing your own anchor bolt, drill the holes using a 1/2 inch masonry bit. If using the provided anchor bolts, drill the holes using a 15 mm masonry bit.



8) Using the provided long bolts, attach the rear of the motor to the bracket.

Installation of Operator

9) Using the **C** measurement from the hinges, find the correct location for your gate bracket. Mark the bracket position and drill $5/16$ " holes in the horizontal bar on the gate. Bolt the bracket to the gate.



10) Insert the $5/16$ " x 2" carriage bolt up from the bottom of the bracket, so the square head of the carriage bolt fits into one of the holes of bracket.

TIP: Most use of the center hole, which is the intended hole of usage. However there are multiple holes for adjustment after the brackets are mounted.

11) Place a washer on top of the bracket and the end of the curved motor arm on top of the washer.

Place a second washer on top of the motor arm and then secure the setup in place using a lock nut. The lock nut should be tightened to hold the bolt in the bracket but not so tight it restricts pivoting.



12) Insert the $5/16$ " x $1\frac{1}{2}$ " carriage bolt through the straight motor arm so the square head fits into the square hole of the arm.

Installation of Operator

13) Flip the bracket so the bolt is facing up. Place a washer between the two arms and join them together.



14) Place another washer on top of the curved bracket that is being joined to the straight bracket. Tighten together using a lock nut so that bolt stays in the square hole, however, it is still loose enough to pivot.

15) Attach the motor arms to the bottom of the motor using the provided bolt.

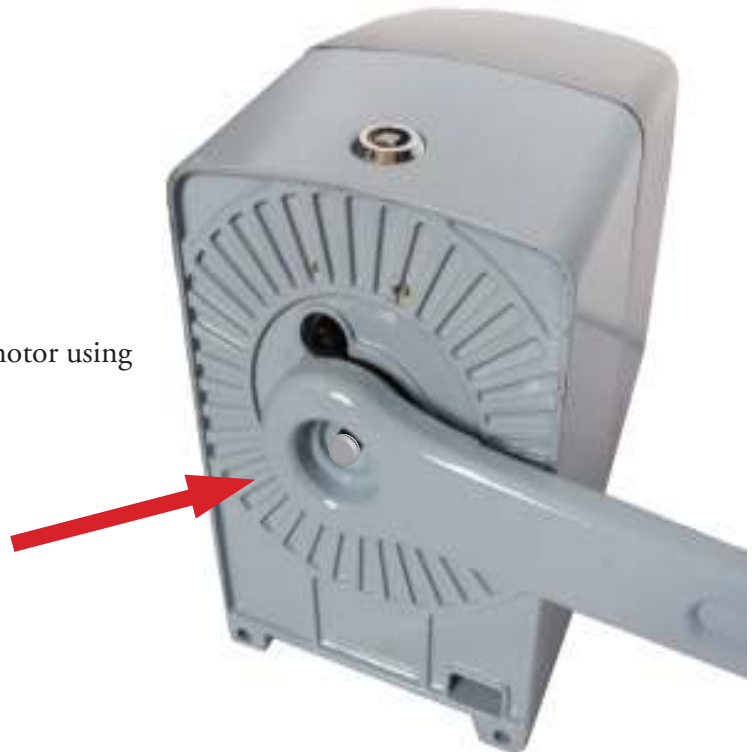

Section 3:

Wiring, Jumpers & Receiver

Control Box & Running Wires

Control Box Mounting:

- The control box can be mounted on a post or fence line.
- If you have a dual operator set up, make sure it is located within 45' of the slave motor.
- Allow at least 3 feet of clearance off the ground.

Wiring:

- Cut to fit the proper water tight connector ring for your wire(s).



It is important that all wires are constricted into the water tight connector.

- Fill in any visible gaps with caulk.

Connecting wires for the slave operator (if applicable):

You will need a second watertight junction box mounted. This item can be found at any hardware store.

Use a bus connector (seen below) to connect the operator pigtail to the wire, which will go under the driveway.

See the next page for instructions on running wire under the driveway. (Applicable for dual gate operation)



Easy Wiring Under Driveway

This portion of the manual will explain how to create an easy conduit for the wires **for dual gates**.

This is what you would need to get started:

- Narrow shovel.
- $\frac{3}{4}$ ' water pipe no more that 5' in length (you would need a total number of pipes that would equal your driveway width plus 1').
- $\frac{3}{4}$ ' electric rigid pipe couplings (one for each joint in the water pipe).
- 1 $\frac{3}{4}$ ' "Tee".
- 1 $\frac{3}{4}$ ' Plug.
- 1 $\frac{3}{4}$ ' male galvanized pipe X female hose fitting (usually in Brass).
- Large hammer.



All the above items could be found in a local home supply store.

Dig a trench perpendicular to the driveway approximately 6 to 8 inches deep and 6' long

Hook up a typical garden hose assembled to the first length of pipe as shown

Turn on water and push the pipe under the driveway, matching the pitch of the driveway.

If you hit a rock use the hammer to force the pipe past the rock.

Attach additional pieces of pipe to the initial length by removing the tee and using the coupling to add the additional length of pipe, reassemble the tee and repeat the above steps until only 6 inches of pipe is sticking out from under the driveway. On the opposite side of the driveway look for a wet spot or water bubbling up, dig to find the end of the pipe.

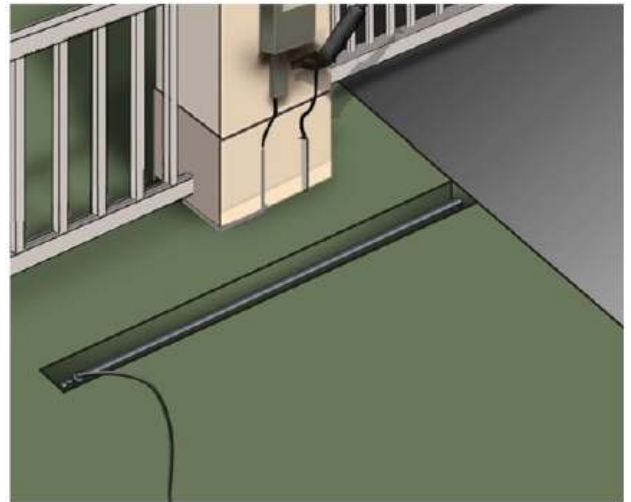

This process is good for driveways up to 24' in width.

For Your Convenience

The green terminal strips on the control board are easily removed for wiring. Simply pull straight out on the terminal strip to remove it from the board. It will slide right off. Slide it back on when you are finished with your wiring connections.

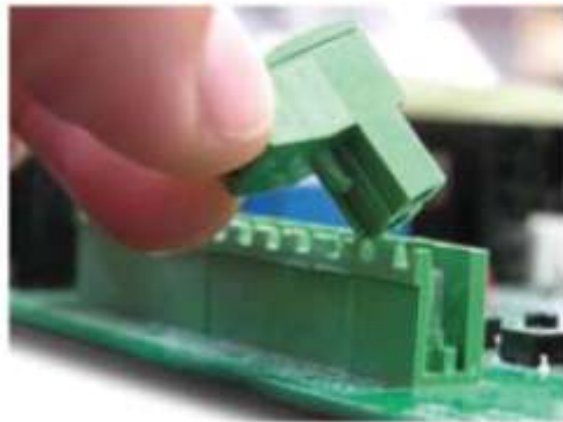

Be sure you are placing your wires in the terminal block correctly.

Take the terminal block off of the control board to insert wires. Hold with screw terminals facing upward.

Turn the screw counter-clockwise to open the terminal and clockwise to close the terminal.

The terminals come closed. Be sure not to mistake this for open and insert the wires below the terminal clamp. This will lack the conductivity to complete the circuit.



Wiring the Motor(s)

Left

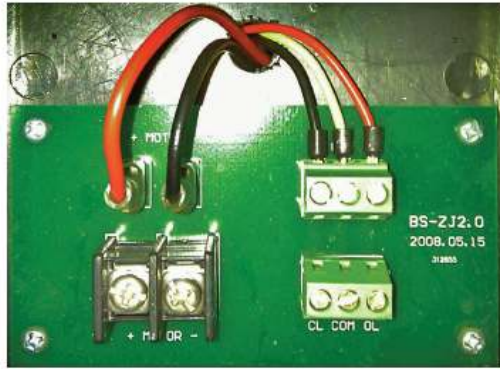

Right



Position of Red / Black Motor Connectors

To turn the drive shaft in the correct direction the red and black motor wires pictured above must be placed according to motor side.

MOTOR on LEFT

Red = Left

Black = Right

MOTOR on RIGHT

Red = Right

Black = Left

*right and left of gate is determined standing inside the property facing the gate.



Wiring

Motor 1

Motor + terminal on motor to Motor 1 - L1-1 terminal on board

Motor - terminal on motor to Motor 1 - L1-2 terminal on board

Limit CL terminal on motor to Limit 1 - CL1 terminal

Limit COM terminal on motor to Limit 1 - V+ terminal

Limit OL terminal on motor to Limit 1 - OL1 terminal

Motor 2 - if dual

Motor + terminal on motor to Motor 2 - L2-1 terminal on board

Motor - terminal on motor to Motor 2 - L2-2 terminal on board

Limit CL terminal on motor to Limit 2 - CL2 terminal

Limit COM terminal on motor to Limit 2 - V+ terminal

Limit OL terminal on motor to Limit 2 - OL2 terminal

Temporary Safety Jumpers & Dip Switch Settings

If you are not using a safety device like a photo eye or safety loop, the Photocell terminal must remain jumped to the GND terminal.

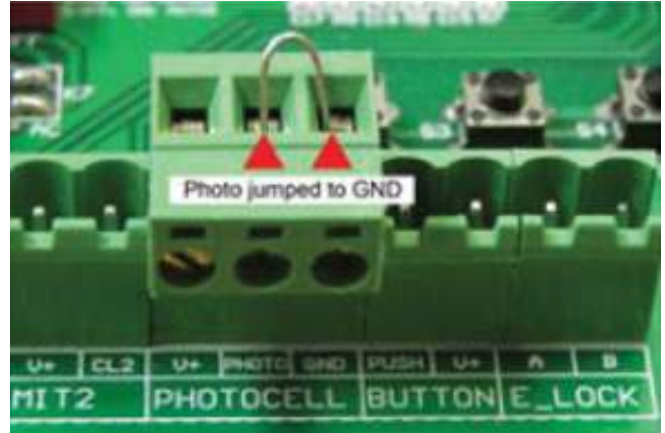

Dip Switches - To change any dip switches, you must turn the power off before changing the setting.

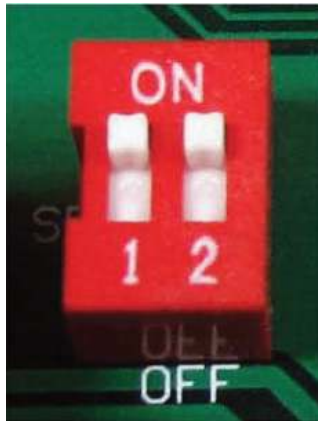

1. ON: Auto-close on (gate will re-close from the open position after a time set in the programming section)
OFF: Auto-Close off
2. ON: Dual gate opener (2 motors)
OFF: Single gate opener (1 motor)



IMPORTANT: We recommend before turning the gate opener on for the first time, to have dip switch 1 **OFF**. If the dip switch is set on, the gate will autoreclose after turning it on without any intentional activation on your part.

Power

The Estate Swing E-SC 400 comes with 1) 24V transformer. The transformer supplied has 2 screw terminals to connect to. You may locate the transformer up to 200' away from the control board using 16 gauge, 2 conductor stranded direct burial low voltage wire. Do not use solid core wire.

Allow a minimum of 4' of wire from the transformer to the control board.

Insert the two wires from the transformer into the two TRAN terminals on the control board. The wires are not polarized, there is no positive or negative. **DO NOT SPLICE THE POWER CABLE WIRE.**



Never run 110VAC power directly to the Estate Swing.

This will destroy the Estate Swing control board. Never connect the power wire with the transformer plugged in. Contact between the two lead wires, even for a second, will destroy the transformer. Transformers are only warranted if the internal fuse is not blown. If the fuse is blown an outside factor (shorting, surge, water, etc) has caused the transformer not to function.

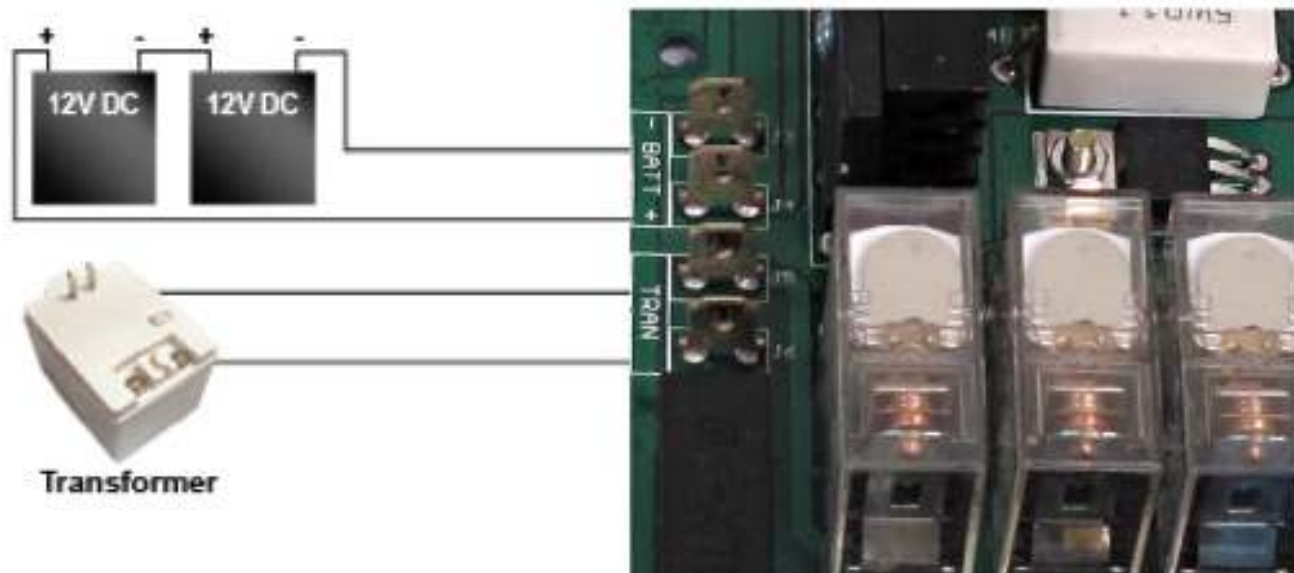

Plug the transformer into a 110 V AC outlet.

The transformer is not weather proof and must be kept in a covered area. Plug covers are available from your dealer, contact 1-800-640-GATE for a dealer in your area.

Two 12V DC batteries (Max 5 a/h per battery) may be run in series as backup to the 24V transformer power. Running two 12V batteries in series creates a 24V system, you cannot run them in parallel (see diagram above)

When you install new batteries - manually open the gate and allow the batteries to charge for 12 hours through the system before using the gate opener.

Section 4:

Start Up and Operation

Set Limit Positions

- 1) To set up limit positions. First release the manual release and move the gate(s) to the closed position.
- 2) Move the limit trip that triggers the top limit switch so that it is triggering the top limit switch in the closed position. The Phillips head screw loosens the limit trip and the flat head screw moves the limit trip. Once you have the limit trip in position, tighten the Phillips head screw so it is locked in place.
- 3) Move the doors open and repeat the above step with the limit trip that triggers the bottom limit switch.

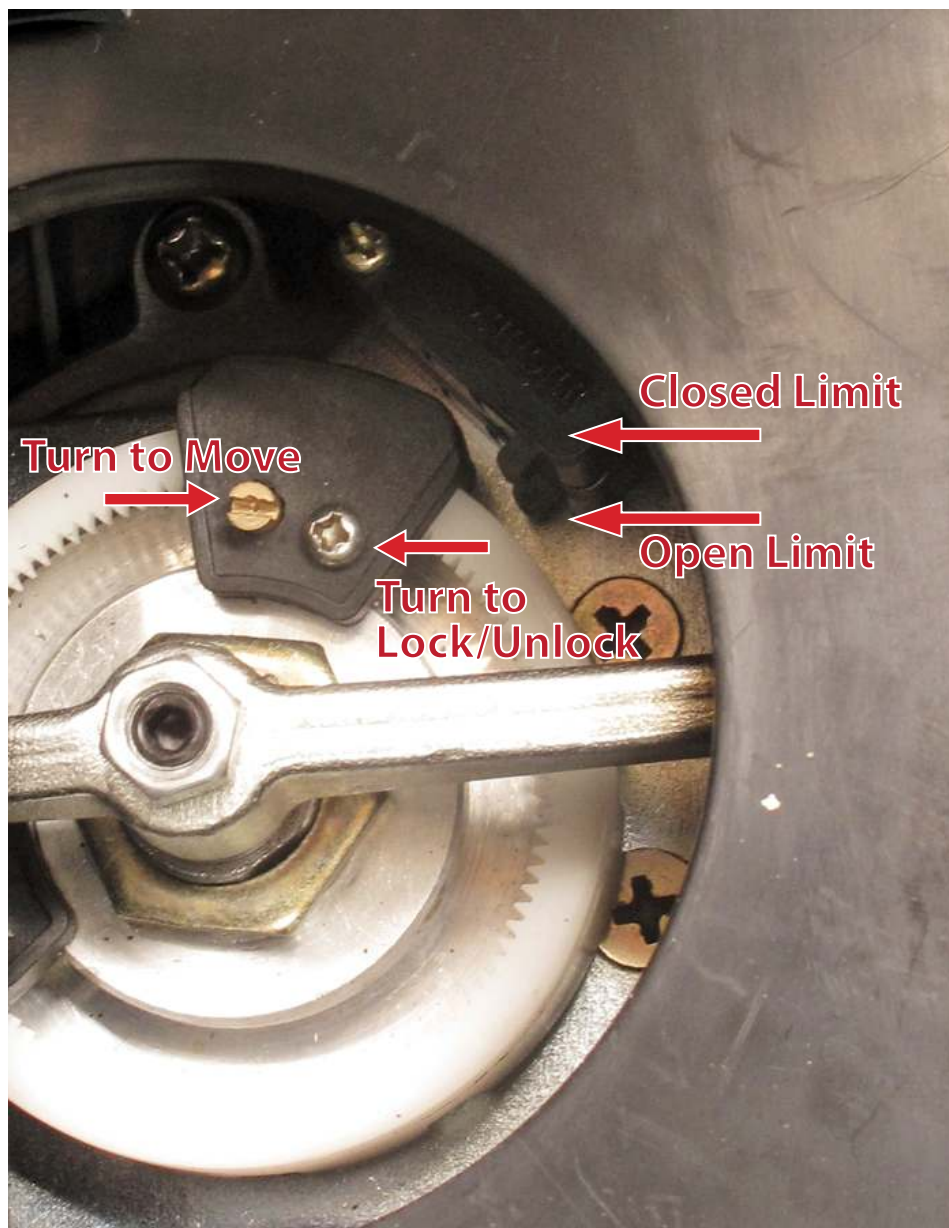

First Run

This is our recommended procedure to run the gate for the first time.

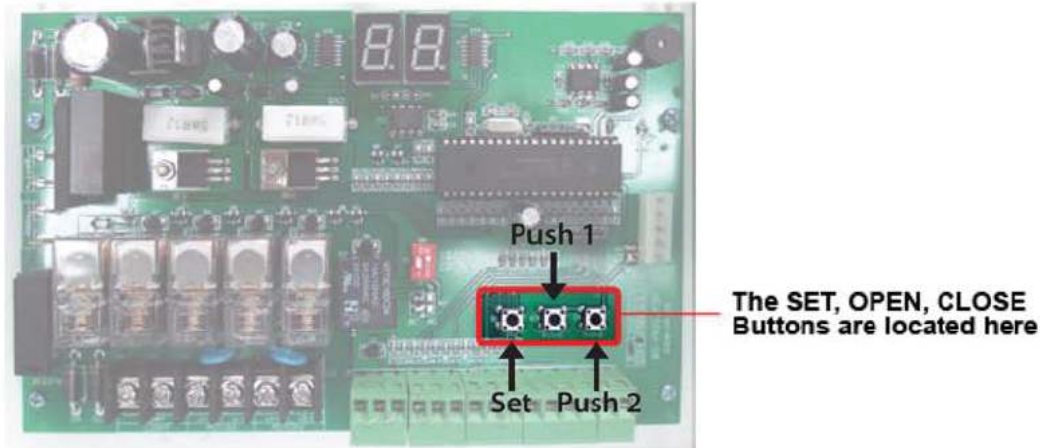

PUSH 1 or PUSH 2 to increase or decrease the parameter. Then press SET button to move to the next parameter.

1. Press SET button to begin.
2. LED shows P1: **Press Push 1 to get P1 setting to 30.**
3. Press SET button.
4. LED shows P2: **Press Push 1 to get P2 setting to 10.**
5. Press SET button.
6. LED shows P3: **Press Push 1 to get P3 setting to 30.**
7. Press SET button.
8. LED shows P4: **Press Push 1 to get P4 setting to 3.**
9. Press SET button.
10. LED shows P5: **Press Push 1 to get P5 setting to 10.**
11. Press SET button.
12. LED shows P6: **Press Push 1 to get P5 setting to 2.**
13. Press SET to finish. You should hear 3 beeps; this indicates parameter programming is finished.

Manually unlock the gate, then move it half-way and re-engage. Activate using Push 1 button (as shown above)
The gate should run open. Press Push 1 again and it should run closed.

The gate is now set up for regular use.

Operating Parameters Customization

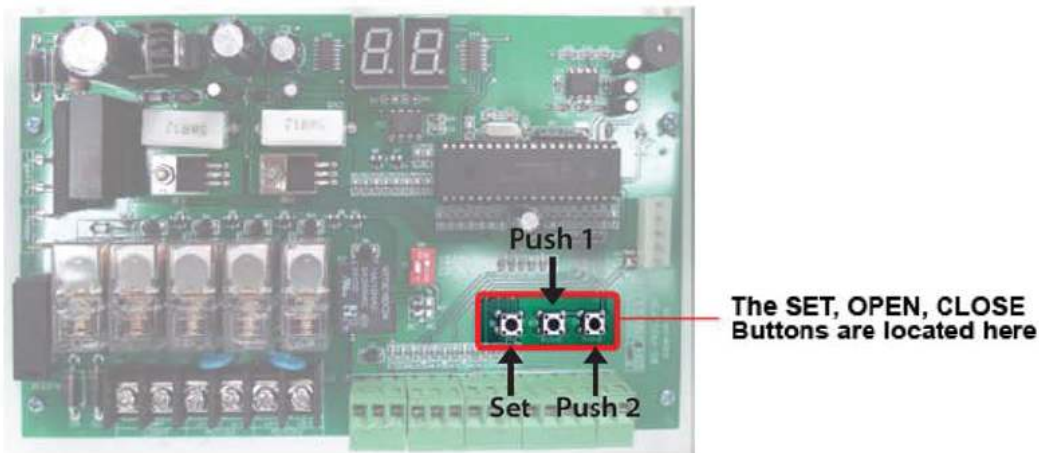

1. LED shows P1: **P1 is for setting your run time.** The run time will be determined from the time you had determined during the set up of the limit switches. Take that determined run time and add 1 second. So if it takes 10 seconds to get from closed to open between limit switches; set the run time to 11 seconds. The options are 0-99 seconds.
2. LED shows P2: **P2 is for setting your slow down time.** The gate opener will slow down to half speed after the time set on P2 expires. If you wish to have the gate open and close faster make the slow down start time a longer period of time. If you want to put less stress on the gears and gate set the slow time shorter to slow the momentum sooner. The options will adjust to match the previously set run time. NOTE: *motor must be in slow down to detect limits - be sure this number does not exceed the time the motor take to move from one limit to the other.*
3. LED shows P3: **P3 is the force setting,** the lower the number the easier the gate will reverse directions when it meets resistance. This number may have to be changed to a higher setting if your gate is obstructing unexpectedly. The number should be set to the lowest number that still gives you reliable gate movement. The options are 0-32.
4. LED shows P4: **P4 is for setting a delay between leafs** if you have overlapping gates or a gate lock. The motor wired into the master terminals (1) opens first if there is a delay and closes second. NOTE: *If one leaf of a dual gate ever reaches its end limit before the other leaf starts moving, the leaf that hasn't started moving will not begin: correct this by cycling the gates again and let it travel the full stroke or decrease the delay between leafs. The options are 0-9 seconds delay.*
5. LED shows P5: **P5 is the delay for automatic re-close** from the open position – this option needs to be turned on using the dip switch on the board. The options are 0-99 seconds.
6. LED shows P6: **P6 is the release for the gate lock** – this option determines the length of time 24VDC will be sent out of terminals E_LOCK. The options are 1-4 seconds.

Section 5:

Troubleshooting and Accessories

Troubleshooting

If the gate opener will not move: (also see “one or both arms are not moving” on next page)

- Check wiring connections.
- If not using slave limit switches, be sure jumpers are in place.
- Be sure the arms are locked and not in manual operation.
- Check the fuse near the power supply—the proper way to inspect a fuse is to remove it from its clips and check for continuity.

If the gate opener move a few inches or feet and stops or reverses directions:

- Increase the force setting (P3).
- Check the setback. The setback of the operator is important to correct operation due to leverage the arm will have on the gate.
- Check the battery voltage. Proper voltage should be between 13.4 - 13.8 and drop no more than a quarter of a volt under load.
- Disconnect accessories that may be triggering the gate a second time. The most frequent issues are from exit sensors or other automatic opening devices.

The gate does not reach the desired stop points:

- Adjust the limit switches.
- Lengthen the run time parameter (P1).
- Check setback - if setback is incorrect it will limit how far the gate will move per inch of stroke length.

If the gate will open but will not close:

- Manually move the gate slightly off the open position and then trigger the gate to go closed. If the gate then moves close, the limits are most likely wired backwards. (Meaning the open limit is wired to closed and closed wired to open)
- If you are **not** using safety devices the safety jumpers are in place. If PH is on display it is an issue with the safety jumper or a device in the safety terminals.
- If you are using a safety device:
 - Check to make sure you are using the normally closed connection instead of the normally open.
 - Check to be sure there is continuity being provided between the common and normally closed wire of the safety device. If there is not continuity then refer to the installation guide of the device to set up properly.

The display of the board will not light up.

- Check the power supply for 24VAC.
- The arms are not wired in or properly wired on the limit switch connections. Without the limit switch connections being closed the board will not light up.

If limit motor is opening or closing past the limits.

- Motor must be in slow down mode to detect limits. Check P2 parameter. The slow down occurs AFTER the number that parameter is set to expires. Example: If P2 is set to 14 and it takes 13 seconds to move from closed to open it will not enter slow down mode. Decrease this number.

Troubleshooting

The gate opener is not stopping on the limit switches

- Remove all pre-installed jumpers from the limit switch terminals that have limits going to them. The slave gate terminals come pre-jumped for single operation, if you are using a dual system pay particular attention to this detail and remove the jumpers when you put your limit switches in.
- The limits are wired incorrectly—be sure that you are following the correct wiring diagram.
- For dual gates, check that the delay between leafs is 2 or above. If both limits are triggered simultaneously, there is a chance a limit could be missed.

One or both arms are not moving

- Check to be sure wiring color pattern matches the installation (Example: push to open wiring for a push to open installation) - If the limits or motor are wiring opposite the installation the board will believe it is closed or open when it is actually the opposite and the arms will never move.
- Check the limit wires are correctly in the terminal blocks. The terminal blocks come with the terminal clamps closed - however when the terminal clamps are closed there is a small space below them one could mistake as place to insert a wire. If this is done than conductivity of the connection will never be reached.
- Push or pull on the gate - if it moves the gears are disengaged and the gate is in manual release mode.

General fix for user to understand operation.

Unlock the gate opener and move it to the half way position. Change the run time to a low number (example: 2). Run the operator repeatedly.

The operator should run one direction for a 2 count and then the other for a 2 count. After you feel you have it following the run time correctly and swinging level and easily, then start incrementally lengthening the run time.

Eventually the run time will allow the operator arm to reach both limit switches and your setup is complete.

Single gate - Arm swings in a jerky manner

The jumpers are not in place on LIMIT 2—all three need to be jumped together.

Dual gate - Only one arm moves

- If one arm reaches a limit before the other arm moves, that other arm will never move. In other words, second arm must move before first hits limit.
- If the device you are using to activate the gate is wired into PUSH 2 that only opens leaf 1.
- Check your dual settings - if the dip switch is changed to dual with the power on the setting will not take effect, turn the power off and then back on to have the dual dip switch take effect.

Troubleshooting



If you call in for technical support or warranty support: Before any control board or motor will be permitted to be sent in for testing or warranty you will be required to e-mail digital photos to the technician.

This is done in your best interest to save unnecessary shipping expenses and time lost. Many times we can come up with solutions to issues by seeing pictures that relay information that is impossible to relay through a phone conversation.

Below is an example of control board picture that we will be looking for:



Control Board Overview



CAUTION! Do not run 110V AC power direct to the board. This will cause permanent damage to both boards and void your warrantee. Caution!

Gate Opener reactions to signals:

PUSH1 and Receiver (PUSH 1 terminal, PUSH 1 button, 5 Prong Receiver):

Details:

- Will activate gate with momentary contact (momentary contact between PUSH1 and V+) or if you momentarily press the PUSH1 button.
- Controls both leaves in 2 leaf mode (Dip switch 2 in the ON position).
- Acts as party mode control to suspend auto-reclose by activating while counting down autore-close in the open position.

Operational Sequence for terminal with autoclose ON (Dip switch 1 in on position):

1. In closed position - momentary contact will open gates.
2. When opening - momentary contact will stop gates and then it will auto reclose.
3. When stopped mid cycle waiting auto reclose - momentary contact will move the gate in the direction opposite what it was moving before stopped.
4. When open and counting auto-reclose pause time - momentary contact will stop pause time.
5. Stopped in open position from override of auto-reclose from PUSH1 or Receiver - momentary contact will reactivate pause time and close gate.
6. When closing - momentary contact will stop the gate and then it will auto reclose.

Operational Sequence for terminal with autoclose OFF (Dip switch 1 in off position):

1. In closed position - momentary contact will open gates.
2. When opening - momentary contact will stop gates.
3. When stopped mid cycle - momentary contact will move the gate in the direction opposite what it was moving before stopped.
4. When open - momentary contact will close gates.
5. When closing - momentary contact will stop the gate.
6. When stopped mid cycle - momentary contact will open the gate.
7. When open with auto-reclose off - momentary contact will have no effect.
8. When closing - momentary contact will re-open the gate.

Control Board Overview



CAUTION! Do not run 110V AC power direct to the board. This will cause permanent damage to both boards and void your warrantee. Caution!

Gate Opener reactions to signals:

PUSH2 (PUSH 2 terminal and PUSH 2 button):

Details:

- Will activate gate with momentary contact (momentary contact between PUSH2 and V+).
- Controls **both** leaves in 2 leaf mode (Dip switch 2 in the ON position).
- **Only opens the gate, never closes it.**
- Pause time is able to be reset indefinitely if this terminal is continuously closed through a non-momentary contact. Then the time will be reset, count down the pause time, and reclose.
- **Ideal for exit wand or exit loop.**

Operational Sequence for terminal with autoclose ON (Dip switch 1 in on position):

1. In closed position - momentary contact will open gates.
2. When opening - momentary contact will have no effect.
3. When stopped mid cycle from PUSH 1 or the Receiver - momentary contact will open the gate.
4. When open with auto-reclose on - momentary contact will reset pause time and will start counting again after release of momentary contact.
5. When pause time countdown is stopped in open from a momentary contact of PUSH 1 or the Receiver - momentary contact will have no effect.
6. When closing - momentary contact will re-open the gate.

Operational Sequence for terminal with autoclose OFF (Dip switch 1 in off position):

1. In closed position - momentary contact will open gates.
2. When opening - momentary contact will have no effect.
3. When stopped mid cycle - momentary contact will open the gate.
4. When open with auto-reclose off - momentary contact will have no effect.
5. When closing - momentary contact will re-open the gate.

PUSH 1 and PUSH 2 – *these terminals can hold as many normally open connections as needed, they will be wired in parallel. They are used for keypads, push buttons, universal receivers, etc.*

Control Board Overview

Light: Sends pulses of 24VDC only while gate is running, and whether it is open or closed

Motor 1: L1-1, L1-2 = 24VDC power to single motor or master motor

Motor 2: L2-1, L2-2 = 24VDC power to slave motor

Limit 1: OL1 = Open limit for single motor or master (normally closed)
V+ = Common for limits +12VDC
CL1 = Closed limit for single motor (normally closed)

Limit 2: OL2 = Open limit for slave motor (normally closed)
V+ = Common for limits, +12VDC
CL2 = Closed limit for slave motor (normally closed)

Photocell: V+ = +12VDC, Max 100 milliamps for photocell power
Photo = Input for safety eye photo beam connection (normally closed)
GND = Ground for photocell power/ground for photo connection

Button: PUSH 1 = Ground for Push 1 Accessory
V + = Positive voltage +12VDC for Push 1 accessory (relay only, not main power)

**PUSH 1 / V+ is for push buttons, keypads, receivers, or any other dry and momentary contact*

PUSH 2 = Ground for Push 2 accessory
V+ = Positive voltage +12VDC for Push 2 accessory (relay only, not main power)

**PUSH 2 / V+ is for exit wand, exit loops or other open only dry contact and momentary contact*

E_Lock: Solenoid lock output -12VDC (4 Amp max)
A = Positive B = Negative

Fuses: F1 = 8A 250V, protects incoming power to board

Control Board Overview

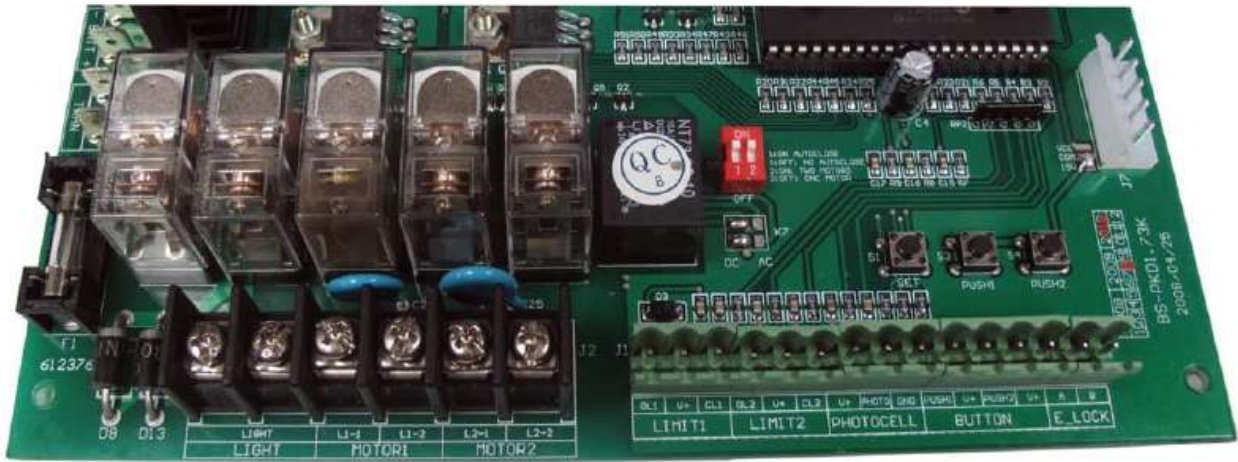

CAUTION! Do not run 110V AC power direct to the board. This will cause permanent damage to both boards and void your warrantee. Caution!

Display Indicators:

Lights off on board & stand by / normal operation

Lower right hand “dots” flashing normal pace:

Awaiting command / normal operation

EL: Sending voltage to EL terminals (electric lock)

OP: Opening cycle

AU: Auto-reclose countdown

CL: Closing cycle

Buzzer / Obstructions:

If the gate(s) come in contact with an obstruction the gate(s) will reverse direction for 3 seconds and stop to allow the obstacle to be cleared from the gate path.

If the gate(s) obstructs 3 times in a row the gate(s) will go into a hard shutdown mode and a buzzer alarm will sound. At this point no accessories or remotes will be able to activate the gate opener until the gate opener is reset by disconnecting primary power (transformer) and secondary power (back up batteries - if applicable).

Installing Accessories

Accessory manuals for most make and model accessories can be found on the web at:

www.EstateSwing.com/accessories

The accessory manuals you have or find at the above address may be written to coincide with that manufacturer's model of gate opener. To determine correct terminals on your Estate Swing operator, use the accessory terminal section of your Estate Swing manual. The following are some common terms and abbreviations found in manuals:

Normally Open – abbr. N/O – Indicates a circuit that is left open during normal operation of the gate operator. When a device closes this circuit it signals the operator to perform a function. This circuit is the main circuit for entry devices. (i.e. keypads, exit wands, push buttons, etc.)

Normally Closed – abbr. N/C – Indicates that in order for the gate opener to be active this circuit must be closed. When a device opens this circuit it stops the motion of the gate operator. This circuit is the main circuit for safety devices. (i.e. photo eyes, safety loops, etc.)

Common – abbr. COM – This is the matching terminal for both Normally Open and Normally Closed circuits to be connected to. Accessory wiring that begins in a N/O or N/O terminal must have a wire that ends in a Common terminal.

Ground – abbr. GND or GRD – Ground is sometimes also known as negative. Common terminals are the same as Ground terminals. Ground can also be the negative spade of the battery if it is being used in association with positive voltage.

If a device has both a N/O and a N/C wire, both are never used at the same time. Some devices can be used as either an opening device or a safety device (i.e. gate crafters exit wand, NIR photo eye, etc.) If being used as an opening device use the N/O and if being used as a safety device use the N/C terminals.