

Instruction Manual for the

Estate SLIDIE

E-SL 1800 Series



!Warning!

Read all instructions before beginning installation or use of this gate opener.

This operator exerts a high level of force.

Exercise caution at all times and stay clear of the system during operation.

Manufactured by

FAAC

An ISO 9001 Certified Company

CE DECLARATION OF CONFORMITY OF MACHINES

(Directive 89/392/EEC, Annex II, Part B)

Manufacturer: FAAC S.p.A.

Address: Via Benini, 1 – 40069 Zola Predosa Bologna – Italy

Declares that: 740 A.K.A. Estate Slide 1800 (USA) mod operator

- Is built to be integrated into a machine or to be assembled with other machinery to create a machine under the provisions of Directive 89/392/EEC, and subsequent amendments 91/368/EEC, 93/44/EEC.
- Conforms to the essential safety requirements of the following EEC directives:
 - 73/23/EEC and subsequent amendment 93/68/EEC, 89/336/EEC and subsequent amendment 92/31/EEC and 93/68/EEC.
 - And also declares that it is prohibited to put into service the machinery until the machine in which it will be integrated or of which it will become a component has been identified and declared as conforming to the conditions of Directive 89/392/EEC and subsequent amendments assimilated under national laws under DPR #459 of July 24, 1996.

Bologna, January 1, 2002

Managing Director

A. Bassi



Warnings for the installer General safety obligations

1. Attention! To ensure the safety of people, it is important that you read all the following instructions. Incorrect installation or incorrect use of the product could cause serious harm to people.
2. Carefully read the instructions before beginning to install the product.
3. Store these instructions for future reference.
4. This product was designed and built strictly for the use indicated in the documentation. Any other use, not expressly indicated here, could compromise the good condition/operation of the product and/or be a source of danger.
5. FAAC declines all liability caused by improper use or use other than that for which automated system was intended.
6. Do not install the equipment in an explosive atmosphere; the presence of inflammable gas or fumes is a serious danger to safety.
7. The mechanical parts must conform to the provisions of Standards EN 12604 and EN 12605.

For non-EU countries, to obtain an adequate level of safety, the standards mentioned above must be observed, in addition to national legal regulations.

8. FAAC is not responsible for failure to observe Good Technique in the construction of the closing elements to be motorized, or for any deformation that may occur during use.
9. The installation must conform to Standards EN 12453 and EN 12445.

The safety level of the automated system must be C+D.

10. Before attempting any job on the system, cut out electrical power and disconnect the batteries.
11. The main power supply of the automated system must be fitted with an all-pole switch with contact opening distance of 3 mm or greater. Use of a 6A thermal breaker with all-pole circuit break is recommended.
12. Make sure that a differential switch with threshold of 0.03 A is fitted upstream of the system.
13. Make sure that the earthing system is perfectly constructed, and connect metal parts of the means of the closure to it.
14. The automated system is supplied with an intrinsic anti-crushing safety device consisting of a torque control. Nevertheless, its tripping threshold must be checked as specified in the Standards indicated at point 10.
15. The safety devices (EN 12978 standard) protect any danger areas against mechanical movement risks, such as crushing, dragging, and shearing.
16. Use of at least one indicator-light (e.g. FAACLIGHT 12VDC) is recommended for every system, as well as a warning sign adequately secured to the frame structure, in addition to the devices mentioned at point "15".
17. FAAC declines all liability as concerns safety and efficient operation of the automated system, if system components not produced by FAAC are used.
18. For maintenance, strictly use original parts by FAAC.
19. Do not in any way modify the components of the automated system.
20. The installer shall supply all information concerning manual operation of the system in case of an emergency, and shall hand over to the user the warnings handbook supplied with the product.
21. Do not allow children or adults to stay near the product while it is operating.
22. Keep remote controls or other pulse generators away from children, to prevent the automated system from being activated involuntarily.
23. Transit through the leaves is allowed only when the gate is fully open.
24. The user must not attempt any kind of repair or direct action whatever and contact qualified personnel only.
25. Do not short-circuit the poles of the batteries and do not try to recharge the batteries with power supply units other than Master or Slave cards.
26. Do not throw exhausted batteries into containers for other waste but dispose them in the appropriate containers to enable them to be recycled.
27. **Anything not expressly specified in these instructions is not permitted.**

Estate Slide Summary of Functions

The Estate Slide is only to be used for vehicular Slide gates in a Class I setting.

Class I: A vehicular gate opener (or system) intended for use in a home of one-to-four single family dwelling, or a garage or parking area associated therewith.

The FAAC Estate Slide automated system was designed and built for controlling vehicle access. Do not use for any other purpose.

The EstateSlide automated system automates residential Slide-leaf gates with leaves of up to 25' in length.

It consists of a locking electro-mechanical linear operator, powered by a 24V AC transformer, coupled with control board that switches the voltage to DC to power the motor. The MASTER card can be programmed and is used to set the following: function logics, work times (by self-learning) and pause times, leaf speed, and the sensitivity of the anti-crushing device.

The locking system will automatically lock when the motor is not operating. A release system enables the gate to be moved by hand in case of a system failure.

For Your Assistance

Keep this manual safely stored after installation.

Serial Number _____







Date of Purchase _____

Place of Purchase _____

Have this information on hand while handling all service and warranty issues.

The table of contents are listed to assist you locating a desired section. We do however strongly suggest studying every page of the instruction manual before attempting installation.

Table of Contents

	PAGE(S):	
• Specifications of the Estate Slide and Components	1.1	
• System Overview & Preliminary Checks	2.1	
• Tools Needed for Installation	3.1	
• Manual Operation	4.1	
• Installation of Base, Operator and Limits	5.1-5	
• Temporary Safety Jumpers, Receiver & Power	6.1-6.4	
• Programming	7.1-7.3	
• Control Board Overview	8.1-8.3	
• Connecting Accessories	9.1	
• Warranty / Troubleshooting Notice	10	



Marks pages with opener or usage warnings. Although we have marked these as very important warnings, **please read the entire manual.** Every step is important to the correct installation of your gate opener.

Specifications

MODEL	Estate Swing
Power Supply	115V AC/ 24V DC
Absorbed Power (W)	3
Absorbed Current (W)	70
Accessory Max Load	500 mA
Torque (Nm)	13.5
Gate speed	3/4' per second
Operating ambient temperature	-4 to 131 Deg F
Operator weight (lbs)	19
Protection class	IP 44
Gate leaf max length (ft.)	Up to 25
Gate leaf max weight (lbs.)	Up to 900
Operator overall dimensions LxHxD(in.)	See below
Type of Limit Switch	Magnetic

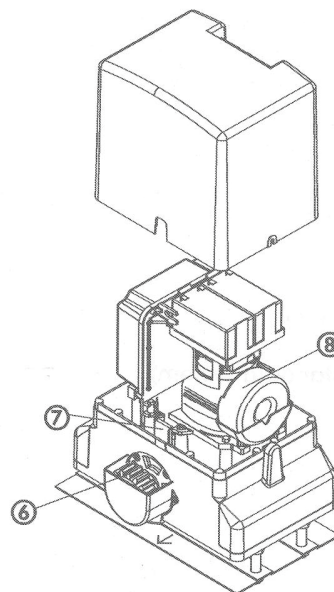
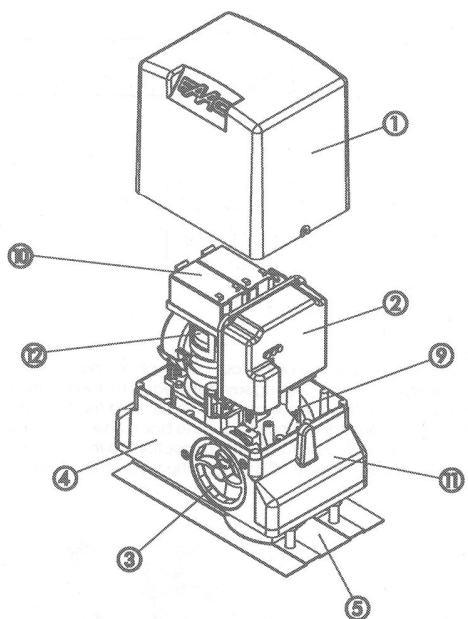

1. Motor lid
2. Electronic control unit
3. Release device
4. Gearmotor body
5. Foundation plate
6. Pinion
7. Limit switch
8. Transformer
9. Cable holes
10. Battery (optional)
11. Protective side panels
12. Encoder

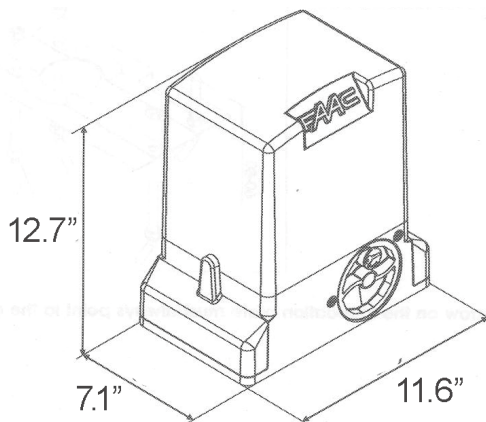
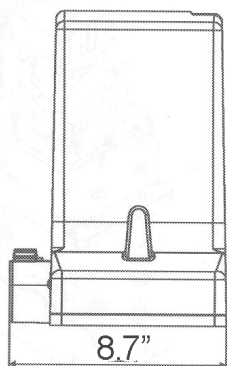

Standard System Overview and Safety Zones

- 1 Estate Swing Operator
- 2 Photocells (not included)
- 3 Key operated pushbutton
- 4 Flashing lamp
- 5 Radio receiver (optional)

The system display to the right is a recommended standard system. Other approved accessories can be installed. Photo sensors and a flashing light indicating gate movement is recommended for safety purposes.



- Notes:**
- 1) Do not extend operator connection cables
 - 2) When laying electrical cables, use appropriate rigid and/or flexible tube
 - 3) Do not run any wires in the same conduit as 110 AC power that may be in the area. This will cause unwanted interference

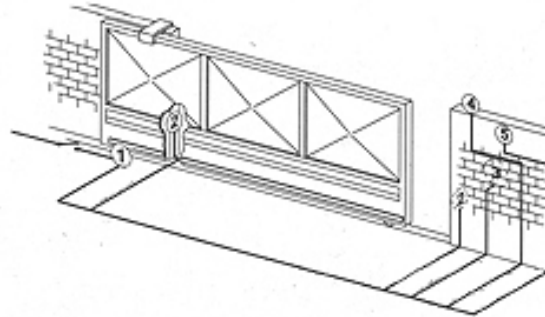

IMPORTANT Preliminary Checks:

To ensure safety and an efficiently operating automated system, make sure the following conditions are observed.

- The gate and post must be suitable for being automated. Check that the structure is sufficiently strong and rigid, and its dimensions and weights conform to those indicated in section 1. In particular, wheel diameter must be in relation to the weight of the gate to be automated. Dimensions and weight must match those indicated in the technical specifications.
- Make sure the leaves move smoothly without any irregular friction during entire travel.
- The soil must permit sufficient stability for the expansion plugs securing the foundation plate.
- Check if the upper guide and travel limit mechanical stops are installed.

We advise you to have any metalwork carried out before the automated system is installed.

Tools Needed



- Power Drill
- Crescent Wrench
- Metal Drill Bits
- Hacksaw
- Flat Head Screwdriver
- Phillips Head Screwdriver
- Tape Measure
- Level
- Wire Strippers
- C-clamps

Other items that may be needed prior to commencing installation.

- **Cement, boards for a slab frame, and a trowel.**
- Low voltage wire will be required to run power to your operator. From 0'-300' 16 gauge 2 conductor stranded direct burial wire will be needed. From 301'-600' 14 gauge 2 conductor stranded direct burial wire will be needed.
- If the gate is more than 600' from an a/c power supply then an electrician will be required to move a supply closer.
- Depending on the current base, you may need cement to form a level mounting pad.
- A voltage meter may be necessary to run diagnostic checks.
- A digital camera will come in handy with technicians if any support is needed.

Manual Operation

1. Open the protective key cover by turning the counter clock-wise.
2. Turn the provided key in the lock.
3. Rotate the dial clockwise.

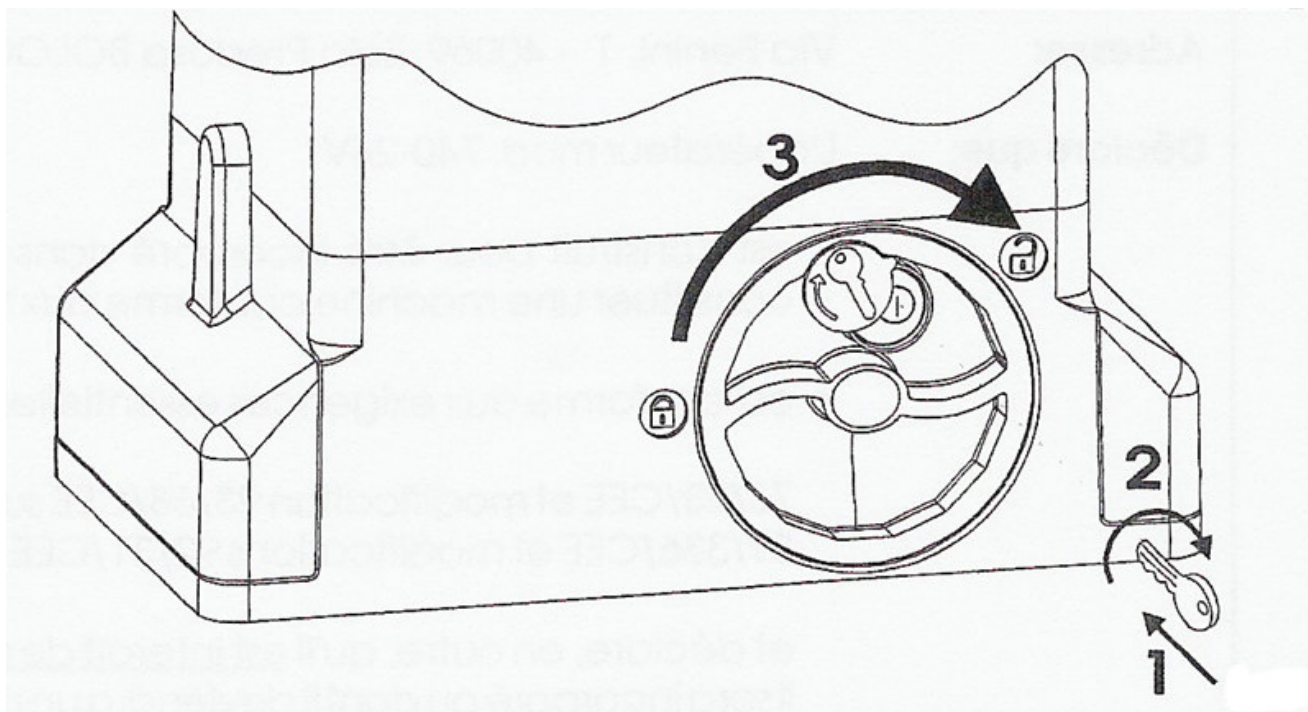

Installation of Mounting Hardware

Set the Foundation Plate

1. Find the distance the foundation plate must be from your gate. The foundation plate must be located as shown in example A (right closing) or example B (left closing) to ensure the rack and pinion mesh correctly. The arrow on the plate **MUST** face the gate.

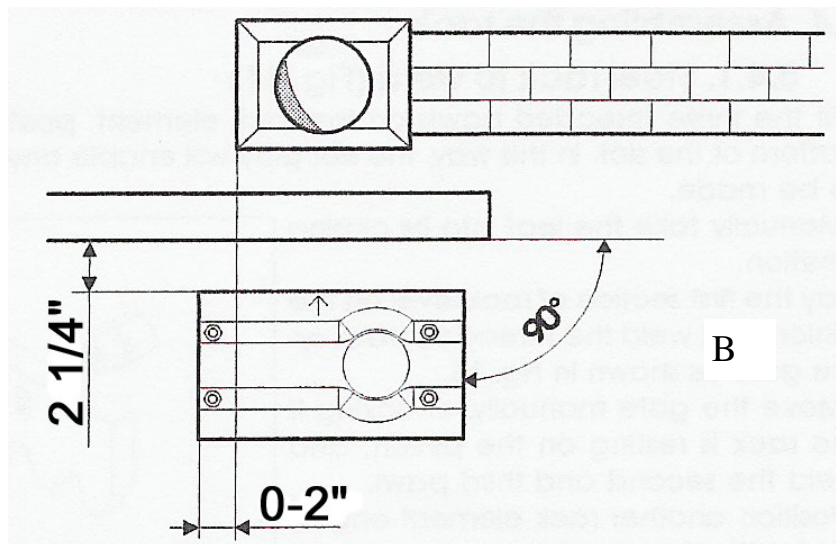
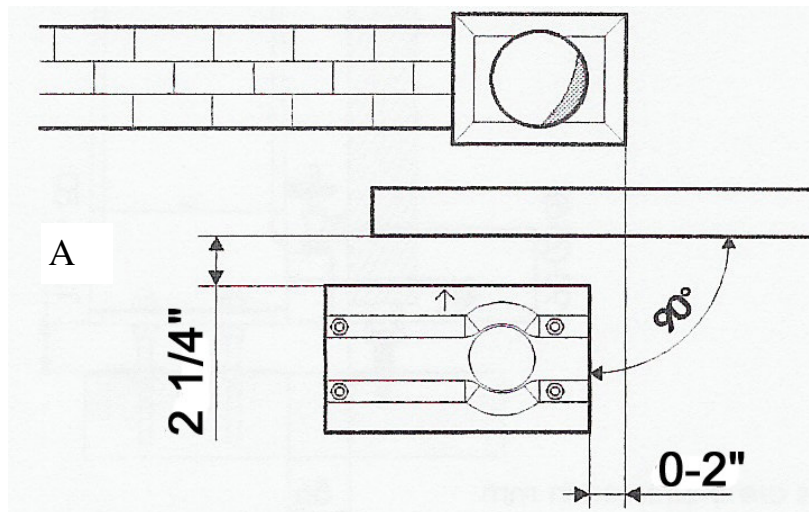

2. Secure the provided bolts to the foundation plate as seen in the diagram below. There should be a nut above and below the plate.

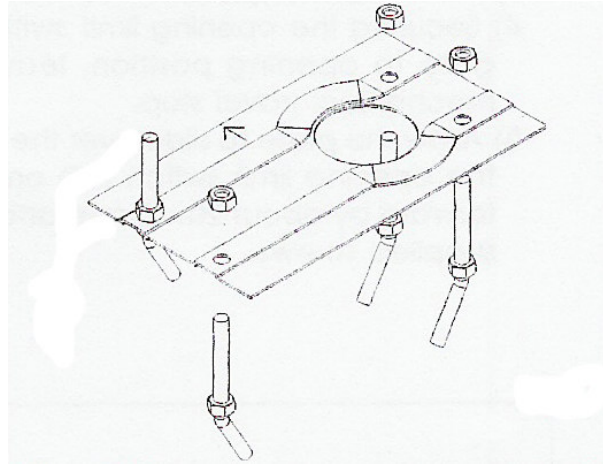

2. Observing the dimensions from step 1, **Create a concrete slab around the bolts.** Create a slab with the dimensions found below. Before pouring the cement set up conduit through the slab to run wires to the operator through. The conduit should line up with the hole in the foundation plate.

Note: If you have a cross bar you are trying to mount the rack on, the center line of the screws that support the rack are 2" from the bottom of the operator. So create your slab to be tall enough to position the bottom of the operator in the correct position. The height of the operator is however adjustable vertically by an inch after the slab is set by adjusting bolts.

All measurements are minimums

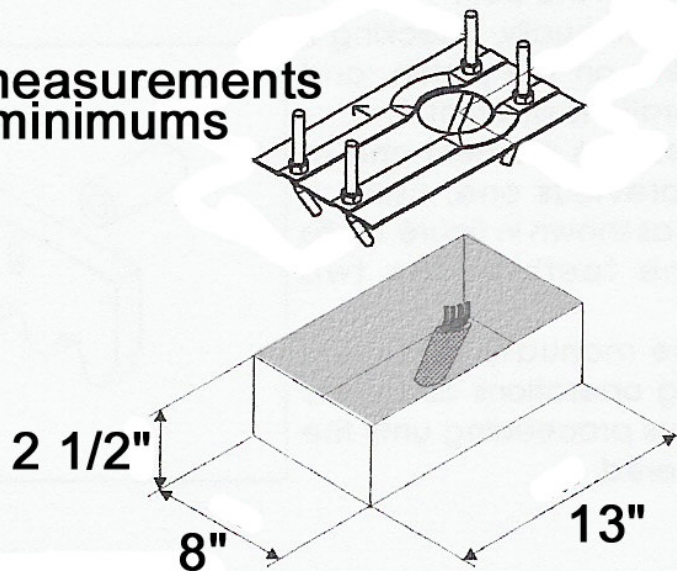

3. **While the concrete is still workable but hard enough to hold the position of the plate,** sit the foundation plate on top of the wet cement. It should be inserted to the bottom of the foundation plate.

Important: check levelness of plate and measurements from gate right away before the concrete sets and the foundation plate is fixed to the pad.

Concrete Slab Tips: Creating a wood rectangle with no top is a good way to form a slab. After the cement dries the wood can be knocked away. The slab must be secured to the ground below. Having rebar pass into the slab works well.

Securing the Operator

1. Position the operator over the foundation plate and slide the treaded part of the bolts through the oblong holes on the outside of the base of the opener.

If the height of the operator from the slab ever has to be adjusted, the nuts just above the plate can be moved up the threading and the operator can rest on the nuts (as seen in the illustration to the right).

2. Feed any wires up through the opener while installing the opener to the base.

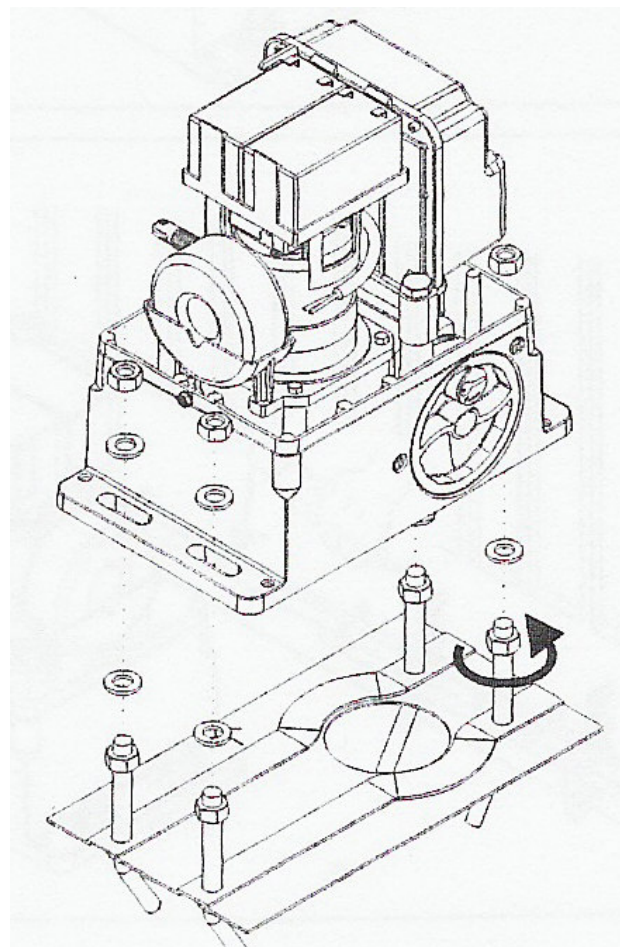

Rack Installation

1. Manually take the leaf to its close position.

2. Lay the first piece of rack at the appropriate level and mark the hole position on the gate. Make a hole and use nuts, bolts and washers to make a connection to the gate (not provided).

The holes in the rack are made oblong for adjustment after the holes are drilled. No special bolts are required for mounting, simply tightening the bolts will hold the rack secure.

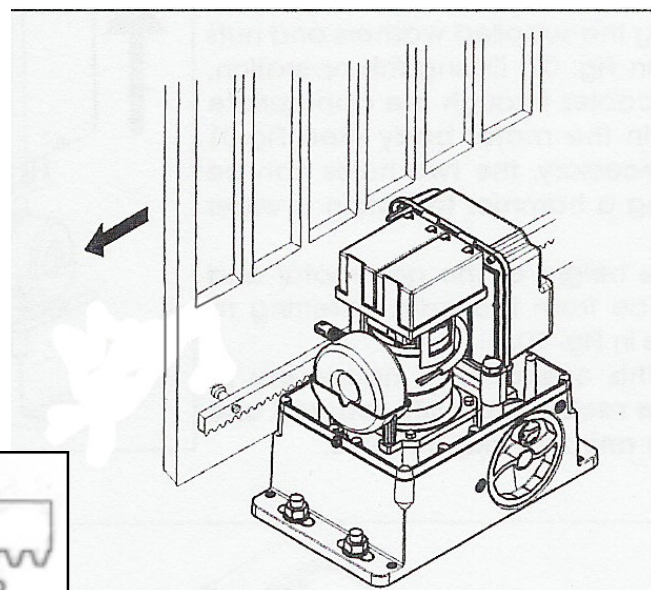
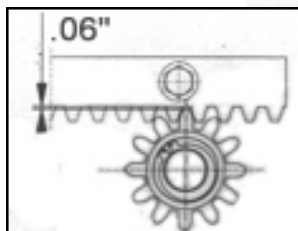

3. Move the gate manually, checking if the rack is resting on the pinion. Repeat at each hole.
4. Bring another rack element near the previous one, using a piece of rack (as shown below) to synchronize the teeth of the two elements.

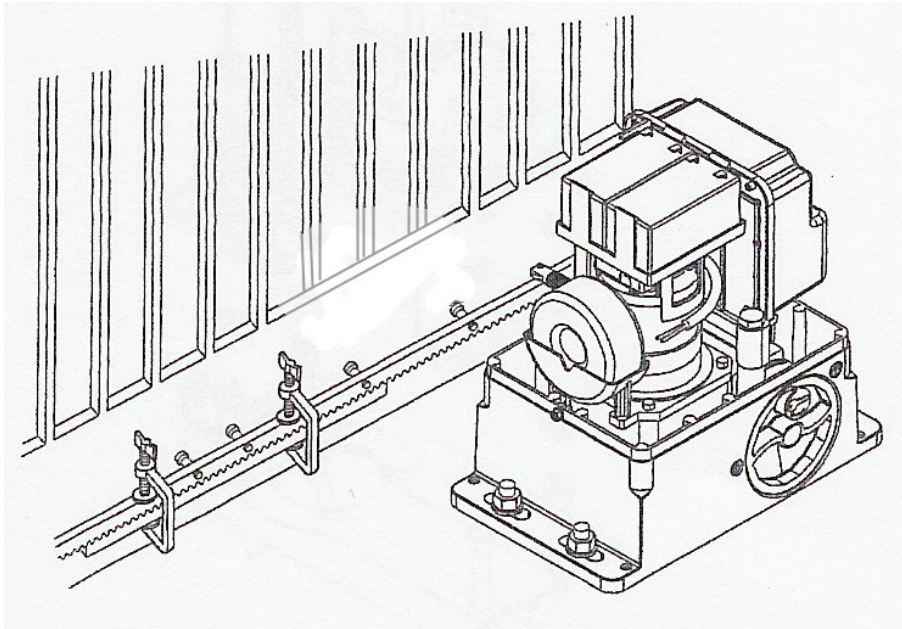

5. Move the gate manually and carry out the securing operations as far as the first element, proceeding until the gate is fully covered.

Notes on rack installation

- Make sure that during the gate travel, all the rack elements mesh correctly with the pinion.
- Do not, on any account, weld the rack elements either to the spacers or to each other.
- When you have finished installing the rack, adjust the distance between the pinion teeth and the rack groove. Check if the distance is .06" (below) along the entire travel using the rack slots.
- Manually check if the gate habitually reaches the travel limit mechanical stops and make sure that there is no friction during gate travel.
- Do not use grease or other lubricants between rack and pinion.

Travel Limit Magnet Installation

The ESTATE SLIDE operator is supplied with a Two magnets that trigger limits built into the motor that need to be secured to the top of the rack. This triggers gate movement to stop in the open and closed position.

1. Move the gate to the closed position.
2. Attach the one of the magnets as seen in the picture so it is triggering the limit.
3. Repeat for open position.

The correct positioning of the closed plate can be checked later after powering up the unit. The FCC limit light (above M2 terminal block) will go off when the closed limit is tripped/ The open limit can be confirmed by the FCA limit light going off.

If the incorrect light is turning off the wires in FCC and FCA on the M2 terminal block must be switched.

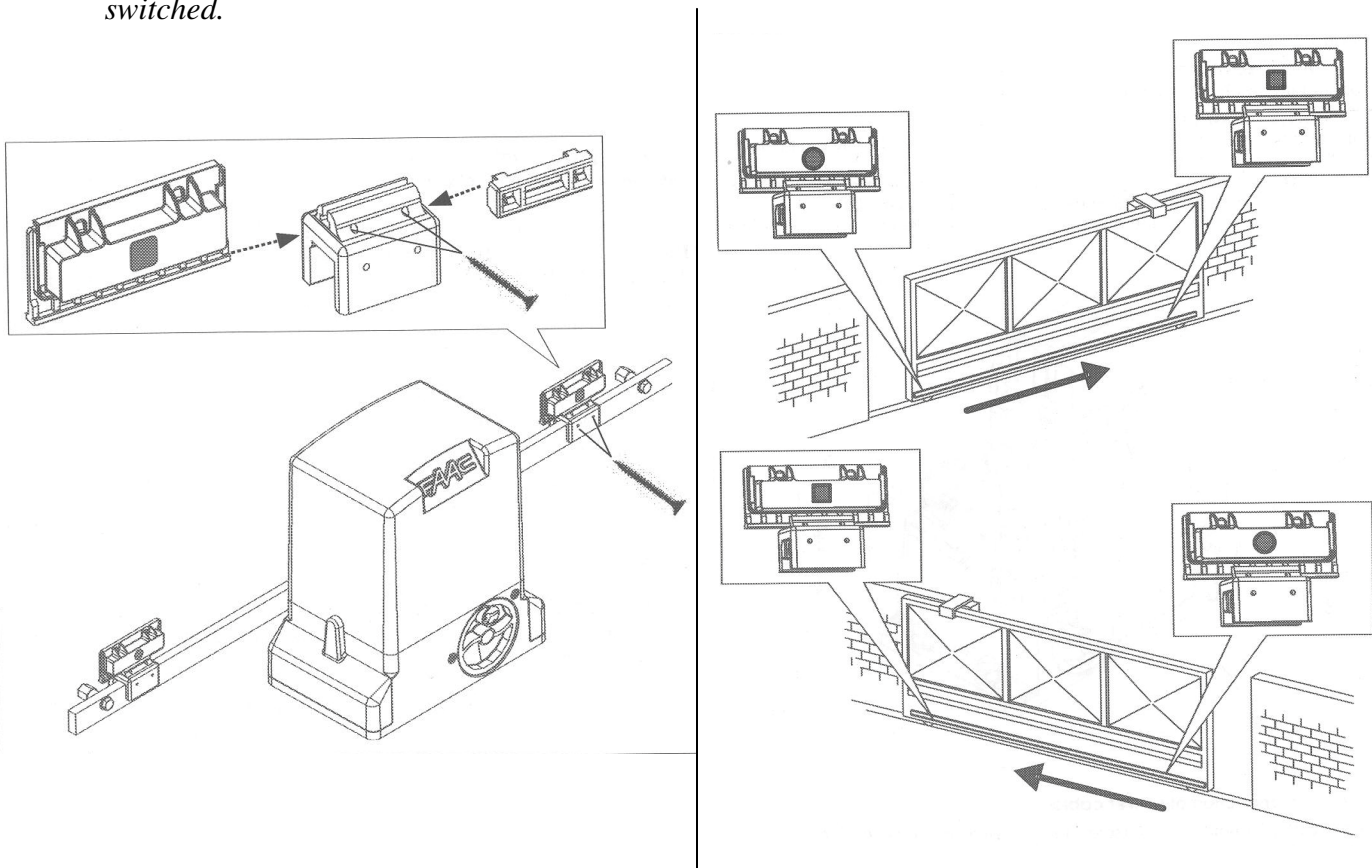

For Your Convenience

The white terminal strips on the control board are easily removed for wiring. Simply pull straight out on the terminal strip to remove it from the board. It will slide right off. Slide it back on when you are finished with your wiring connections.

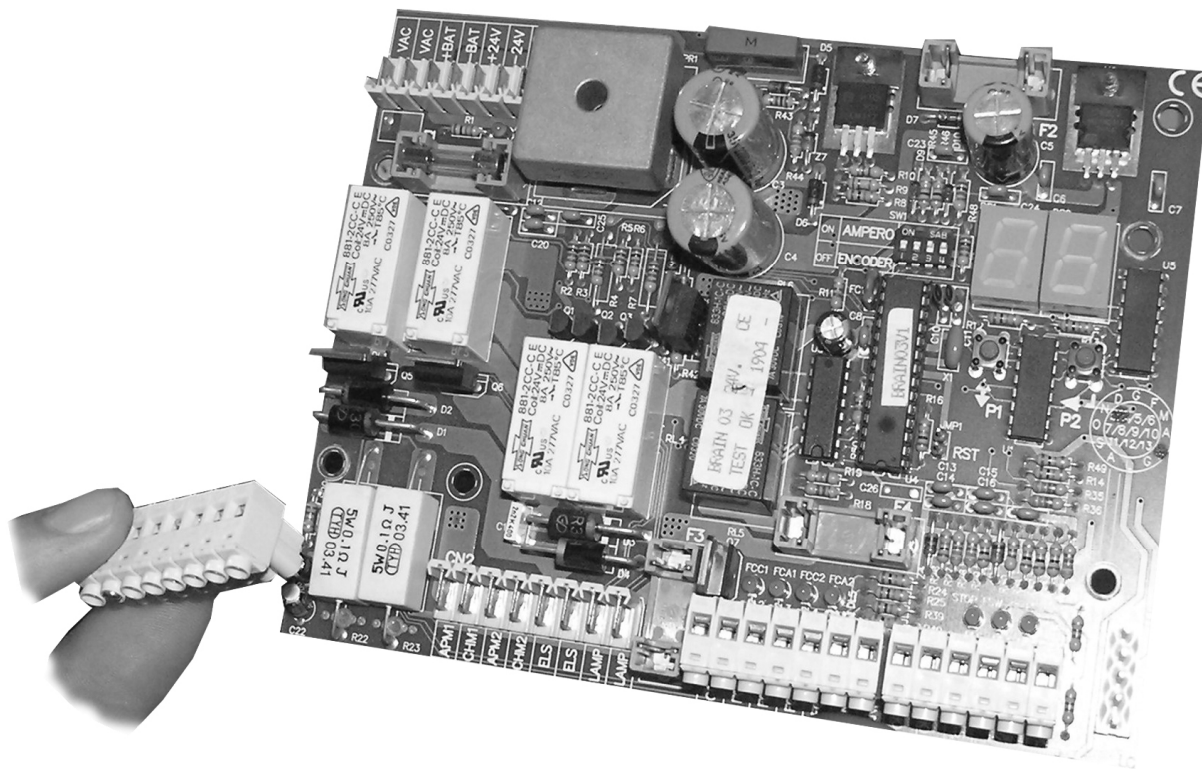

Installing and Setting Transmitters and Receivers

Installing the Receiver

- 1) Locate the 5 Silver Pins in the lower right hand corner of the Estate Swing board.
- 2) Locate the **white** connector on the receiver.
- 3) Push the **white** connector from the receiver on the 5 pins on your FAAC board.

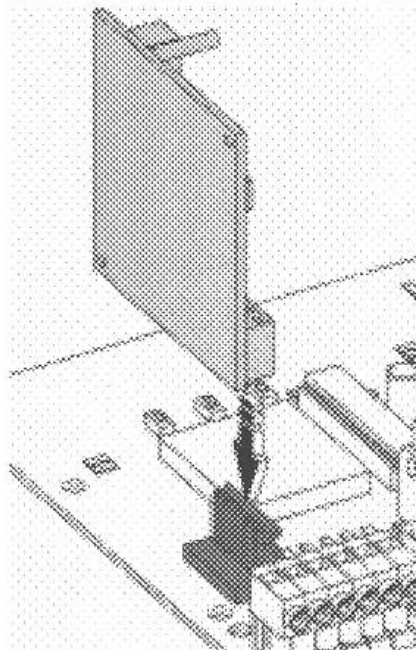

Setting the Dip Switches

- 1) Set the dip switches 1-9 on the receiver by switching them in the up or down position.
Record this dip switch combination
- 2) Slide off the battery cover of the transmitter (*located at the bottom front cover*)
- 3) Set the dip switches in the transmitter to the same settings as the dip switches on the receiver.
- 4) Repeat this for all of the transmitters.



Dip switches are located under the battery lid.

Power

1. The Estate Swing E-SL 1800 comes with 1) 24V transformer. The transformer supplied has 2 screw terminals to connect to. You may locate the transformer up to **144'** away from the control board using 2 conductor stranded direct burial wire as specified below.

- 0-36 Feet - Use 16 Gauge
- 37-57 Feet - Use 14 Gauge
- 58-91 Feet - Use 12 Gauge
- 92-144 Feet - Use 10 Gauge

2. Insert the two wires from the transformer into the two VAC terminals on the control board (CN1). The wires are not polarized, there is no positive or negative. **Do not splice the power cable wire.**



Never run 110VAC power directly to the Estate Swing control board.

Never connect the power wire with the transformer plugged in. Contact between the two lead wires, even for a second, will destroy the transformer.

Transformers are only warranted if the internal fuse is not blown. If the fuse is blown an outside factor (shorting, surge, water, etc) has caused the transformer not to function.

3. Plug the **transformer** into a 110 V AC outlet.
4. The transformer is not weather proof and must be kept in a covered area. *Plug covers are available from your dealer, contact 1-800-640-GATE for a dealer in your area.*
5. Two 12V DC batteries may be run in series as backup to the 24V transformer power. Running two 12V batteries in series creates a 24V system, **you cannot run them in parallel (see diagram)**
6. The power light located below the +24V and -24V output terminals will be on if the power is connected properly. If the light is off then power through the transformer is not functioning properly and either the unit has no power or is on battery backup. *The light stays off during battery backup.*

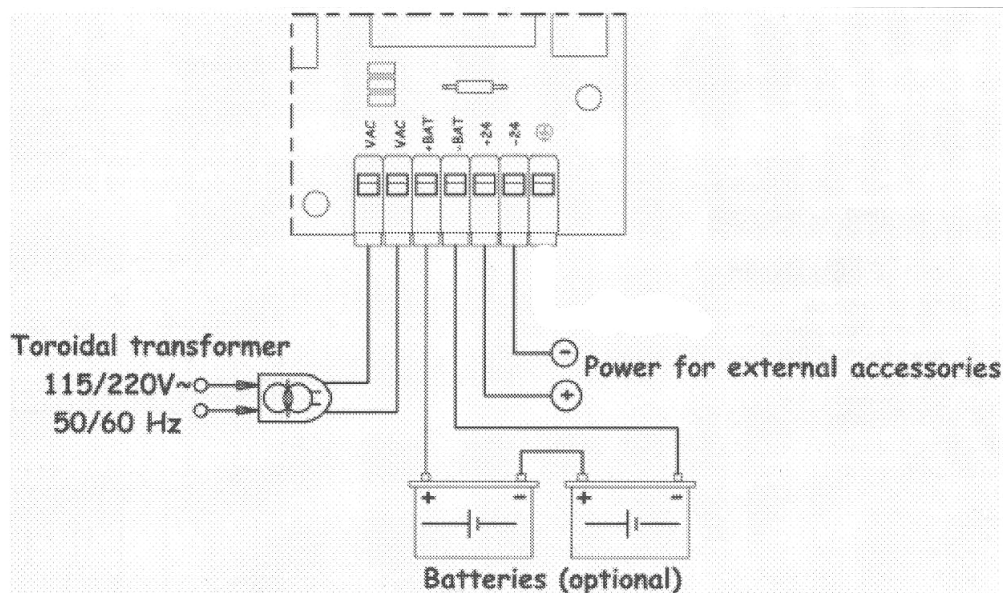

Temporary Safety Jumpers

For the highest level of safety, the Estate Swing systems are set up with Normally Closed safety terminals. This means that in order for the gate opener to move these terminals must be closed either through a safety device (recommended) or with jumpers. Temporary safety jumpers are provided in the control box hardware bag for jumping these terminals to common (COM) during the set-up process.

It is recommended not to use any accessories until setup and programming are complete.

NOTE: If not using safety devices the temporary safety jumper must remain in. In order for the gate operator to move, all three safety terminal lights (STOP, FSW CL, FSW OP) must be lit.

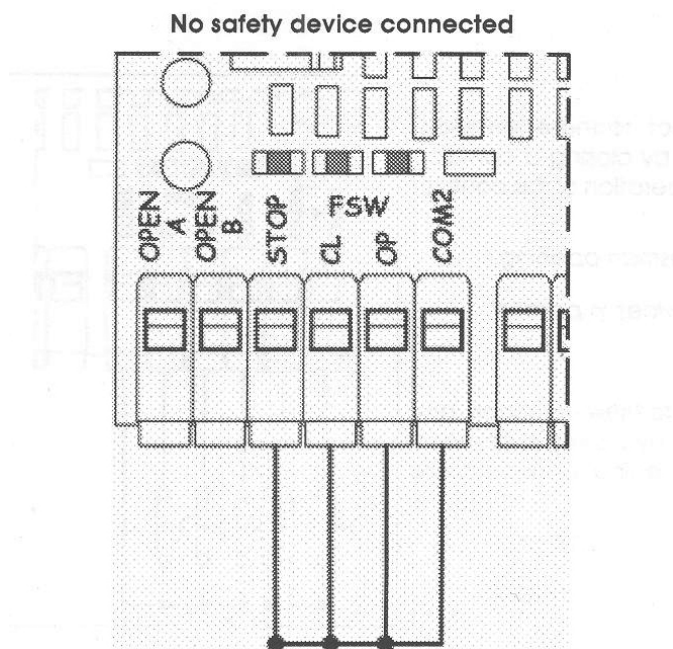

NOTE: The lights will not come on until the power is applied to the board in the next step, but the connections should be made prior to that.

Programming Operating Parameters



Complete this step prior to programming the gate movements. This will dictate how your gate will react during programming.

If you do not use a backup battery and lose power or if you must disconnect all power during programming to reset your control board, you **MUST** start at this step before programming movements or operating your gate, all parameters return to default.

NOTE: there are 3 buttons on the casing but only two make contact with P1 or P2, the other is there for a different model opener and should be ignored.

Entering programming mode

1. Make the necessary power connections and check the LED lights to be sure the appropriate lights are lit.
2. The display should show
3. Press and hold down **P2** until the display shows parameter A with the corresponding number that is currently default or previously programmed.
4. Press **P1** to change the number variable of the parameter, **USE THE CHART ON THE NEXT PAGE AS A GUIDE.**
5. To move to the next parameter, Press **P2**.
6. When 60 seconds have elapsed without any button being pressed the control unit automatically exits the programming mode. To exit manually, Press **P2** to scroll through all the parameters until the display shows

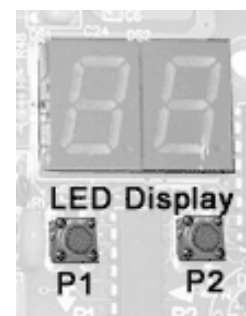

Operating Parameters Chart

A1, A2, A3, A4	Force: 1 = Obstructs easily, 4 = Obstructs less sensitive Obstruction is when gate meets resistance motor stops and reverses directions
C0, C1	0 = Auto reclose off, 1 = Auto reclose on Time delay set during run time learning process
D0, D1	0 = open/close/open, 1 = open/stop/close/stop Sequencing when remote or OPEN A is triggered
E0, E1	0 = Condo function off, 1 = Condo function on Condo function ignores signal from OPEN A or remote during an open cycle
G0, G1	0 = Flashing lamp, 1 = Steady on lamp (2 minute) For 24V lamp terminal output
H1, H2, H3, H4	1 = 10%, 2 = 20%, 3 = 30%, 4 = 40% Percentage of run time in slow down
I0, I1	0 = Slow down speed quarter speed, 1 = slow down speed half speed
L0, L1	0 = encoder only, 1 = limits and encoder Encoder is a device that records number of motor turns from closed to open Recommended to use 1 setting
N0, N1	0 = pre-flashing off, 1 = pre-flashing on For 24V lamp terminal, pre-flashing is a delay that allows lamp to flash before closing as a warning of closing about to occur
O0, O1	0 = photocell close off, 1 = photocell close on When open and in auto-reclose count down, photo cell wired in closing safety if triggered and released makes gate close immediately
P0, P1	0 = auto-reclose override off, 1 = auto-reclose override on Auto-close override is a trigger from OPEN A or remote causes auto-reclose to be skipped and gate to close immediately
R0, R1	0 = Final brake off, 1 = Final brake on If on there is a slight braking to decrease remaining momentum before stopping

After programming your last parameter you may now move on to programming your gate movement. Press P2 one more time to exit this mode. Gate movement instructions begin on the next page.

Programming Gate Movements

In this stage, your control board will memorize run time so it may judge where to begin slowing down for the soft stop feature. Also if the auto-close feature is activated it will learn the user specified pause time.

1. Release the operator gears using the manual release process. Once released, manually move the gate half way between the open and close position (this does not need to be exact).
2. Relock the operator gears at the half way point through its cycle. Verify your operator control board is showing — — on the LED display.
3. Press and hold down **P2** until the LED display shows the A parameter and the relevant number appear in the LED display.
4. Give an **OPEN A** command. This can be done with any opening device (keypad, push button, etc...) wired into OPEN A and COM **or** by using the transmitter. You can also briefly (one second or less) jump OPEN A and COM with a wire. This will begin your gate in the **CLOSING DIRECTION** and the LED display will read **“Pr”**.

IMPORTANT: If the gate begin to open rather than close, the gate must be stopped with a reset pulse. You can either:

Touch the TWO pins of the JMP “RESET” using a screwdriver **OR** Disconnect all power (transformer and backup battery)

Then switch the wires leading into APM1 and CHM1. Also switch the wires between FCC and FCA.

5.

When the closing limit switch is reached, the motor pauses for approximately 2 seconds, and then re-starts with a total opening maneuver to the opening stop limit switch.

6. When the full open stop or limit switch is reached the gate will stop.
7. Wait for the amount of time you would like your gate to pause for during normal operation before automatically re-closing and then signal your opener using an OPEN A contact or transmitter signal to close the gate. The gate will then return to closed and programming will be complete.

(Even if your auto close is off you must still set a pause time, the pause time will not be used in normal gate operation.)

LED Lights & Operational Displays

Control Board LED Lights - The control board LED lights are located above their respective terminals that they represent. (With exception of ALIM, power supply light) The LED lights are a quick way of verifying necessary connections are made. Below is a chart of their interpretations.

LED	ON	OFF
ALIM	Powers supply by transformer	Power supply by battery or no power
FCC	Closing limit switch - not tripped	Closing limit switch - tripped
FCA	Opening limit switch - not tripped	Opening limit switch - tripped
STOP	Stop command - not activated	Stop command - activated
FSW CL	Closing safety device - not tripped	Closing safety device - tripped
FSW OP	Opening safety device - not tripped	Opening safety device - tripped

During idle for dual gate openers, all LED lights should be on.

If not using safety devices , you must jump STOP, FSW CL and FSW OP to COM in order for the gate opener to function.

Standard Operation Display - This is when the gate opener is not in parameter setting mode or programming mode. LED displays DS1 and DS2 will show the following:

Gate Status

— — Gate At Rest in Closed Position

 Gate Opening or Gate Open when Auto Close is OFF

 Gate open in pause status
(Only with automatic re-close enabled - Parameter c)

 Gate Closing

Control Board Overview



Caution! Do not run 110V AC power direct to the board. This will cause permanent damage to both boards and void your warrantee. **Caution!**

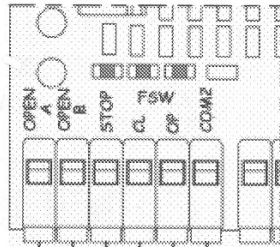

M1 - Located on the bottom left of the board, these terminals are for accessories and safety devices.

- **OPEN A - terminal.** This is the most common terminal for accessories. Accessories utilizing a normally open contact to set the gate in motion will be attached to this terminal and the COM terminal (common or also know as ground).
- **OPEN B - terminal.** This terminal is for opening the first leaf only in dual gate operations. It is a normally open contact that must be used in conjunction with the COM terminal.
- **STOP - terminal.** This is a normally closed terminal that is used for gate motion stopping emergency commands. **If a safety device is not being used in this terminal the operator must have a jumper ran from this terminal to the COM terminal in order to operate.**
- **FSW CL, FSW OP - terminals.** These normally closed terminals are for safety devices during the closing (CL) and opening (OP) cycles of the gate. **If a safety device is not being used in this terminal the operator must have a jumper ran from this terminal to the COM terminal in order to operate.**
- **COM2 - terminal.** This is a common, or sometimes referred to as ground, terminal. It is used in conjunction will **ALL** accessories and safety devices.

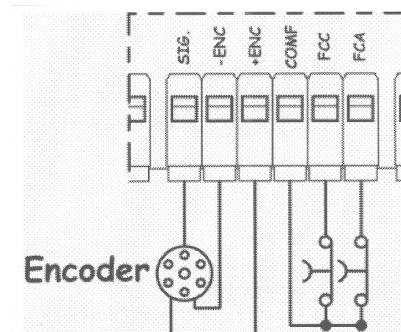

M2- Located on the left center bottom of the board, these terminals are for limit switches.

- **SIG., ENC1, ENC2 - terminals.** Already connected, do not disconnect.
- **COMF** - Common terminal to make the needed normally closed connections for the limit switches.
- **FCC** - Normally closed contact. This terminal is connected with the COMF through the limit switch. When tripped (connection opened) it stops the motion of the first operator. *(If not being used, this terminal must be jumped with COMF)*
- **FCA** - Normally closed contact. This terminal is connected with the COMF through the limit switch. When tripped (connection opened) it stops the motion of the first operator. *(If not being used, this terminal must be jumped with COMF)*

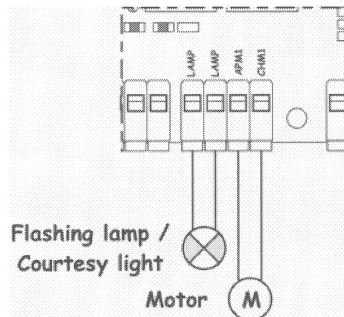

M3 - Located on the right center bottom of the board, these terminals are outputs for the operator arm, and lamps (optional).

- **LAMP - terminals.** A flashing lamp can be connected to these terminals with a power supply of 24V DC and a max output of 15 W. Use a steady light, the flashing is produced by the control board.
- **APM, CHM - terminals.** These terminals are the output for controlling the operator motor. If the operator is moving in the wrong direction swap these two terminals

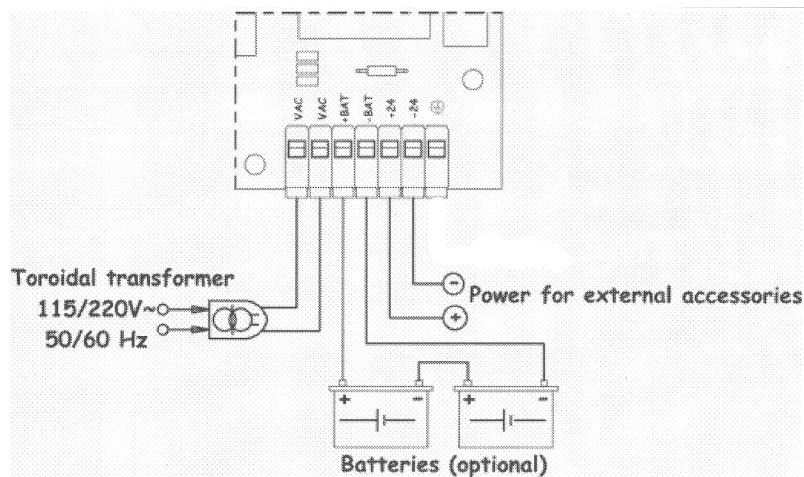

M4 - Lower right hand corner of board, used for power and back up power.

- **VAC - terminals.** The input terminals for the supplied 24V transformer. Polarity is not an issue for this terminal.
- **+BAT, -BAT - terminals.** Input terminals for the optional backup batteries. The battery power coming in must be 24V DC. This can be achieved by running two 12V batteries in series. During normal operation, the unit keeps the batteries charged and the batteries begin operating the unit if no power is being supplied through terminals VAC. Observe polarity on these terminals.
- **+24, -24 - terminals.** Accessories needing constant 24V power should be attached to these terminals following the correct polarity. (Example: Alternate receiver, exit wand)

Installing Accessories

Accessory manuals for most make and model accessories can be found on the web at:

www.EstateSwing.com/accessories

The accessory manuals you have or find at the above address may be written to coincide with that manufacturer's model of gate opener. To determine correct terminals on your Estate Swing operator, use the accessory terminal section of your Estate Swing manual. The following are some common terms and abbreviations found in manuals:

Normally Open – abbr. N/O – Indicates a circuit that is left open during normal operation of the gate operator. When a device closes this circuit it signals the operator to perform a function. This circuit is the main circuit for entry devices. (i.e. keypads, exit wands, push buttons, etc.)

Normally Closed – abbr. N/C – Indicates that in order for the gate opener to be active this circuit must be closed. When a device opens this circuit it stops the motion of the gate operator. This circuit is the main circuit for safety devices. (i.e. photo eyes, safety loops, etc.)

Common – abbr. COM – This is the matching terminal for both Normally Open and Normally Closed circuits to be connected to. Accessory wiring that begins in a N/O or N/C terminal must have a wire that ends in a Common terminal.

Ground – abbr. GND or GRD – Ground is sometimes also known as negative. Common terminals are the same as Ground terminals. Ground can also be the negative spade of the battery if it is being used in association with positive voltage.

If a device has both a N/O and a N/C wire, both are never used at the same time. Some devices can be used as either an opening device or a safety device (i.e. gate crafters exit wand, NIR photo eye, etc.) If being used as an opening device use the N/O and if being used as a safety device use the N/C terminals.

Warranty / Troubleshooting Notice



If you call in for technical support or warranty support: before any control board or motor will be permitted to be sent in for testing or warranty you will be required to e-mail digital photos to the technician.

This is done in your best interest to save unnecessary shipping expenses and time lost. Many times we can come up with solutions to issues by seeing pictures that relay information that is impossible to relay through a phone conversation.

Below are examples of control board pictures and motor pictures that we will be looking for:

