

# Instruction Manual for the



## Heavy Duty Series Carriage Door Instructions



### **!Warning!**

Read all instructions before beginning installation or use of this door opener.

This operator exerts a high level of force.

Exercise caution at all times and stay clear of the system during operation.

Manufactured by



## CE DECLARATION OF CONFORMITY OF MACHINES

(Directive 89/392/EEC, Annex II, Part B)

Manufacturer: FAAC S.p.A.

Address: Via Benini, 1 – 40069 Zola Predosa Bologna – Italy

Declares that: Eurotrigon 0224 - Trigon K 24 A.K.A. Estate Swing (USA) mod operator

- Is built to be integrated into a machine or to be assembled with other machinery to create a machine under the provisions of Directive 89/392/EEC, and subsequent amendments 91/368/EEC, 93/44/EEC.
- Conforms to the essential safety requirements of the following EEC directives:
  - 73/23/EEC and subsequent amendment 93/68/EEC, 89/336/EEC and subsequent amendment 92/31/EEC and 93/68/EEC.
  - And also declares that it is prohibited to put into service the machinery until the machine in which it will be integrated or of which it will become a component has been identified and declared as conforming to the conditions of Directive 89/392/EEC and subsequent amendments assimilated under national laws under DPR #459 of July 24, 1996.

Bologna, January 1, 2002

Managing Director  
A. Bassi



### Warnings for the installer General safety obligations

1. Attention! To ensure the safety of people, it is important that you read all the following instructions. Incorrect installation or incorrect use of the product could cause serious harm to people.
2. Carefully read the instructions before beginning to install the product.
3. Store these instructions for future reference.
4. This product was designed and built strictly for the use indicated in the documentation. Any other use, not expressly indicated here, could compromise the good condition/operation of the product and/or be a source of danger.
5. FAAC declines all liability caused by improper use or use other than that for which automated system was intended.
6. Do not install the equipment in an explosive atmosphere; the presence of inflammable gas or fumes is a serious danger to safety.
7. The mechanical parts must conform to the provisions of Standards EN 12604 and EN 12605.

For non-EU countries, to obtain an adequate level of safety, the standards mentioned above must be observed, in addition to national legal regulations.

8. FAAC is not responsible for failure to observe Good Technique in the construction of the closing elements to be motorized, or for any deformation that may occur during use.
9. The installation must conform to Standards EN 12453 and EN 12445.

The safety level of the automated system must be C+D.

10. Before attempting any job on the system, cut out electrical power and disconnect the batteries.
11. The main power supply of the automated system must be fitted with an all-pole switch with contact opening distance of 3 mm or greater. Use of a 6A thermal breaker with all-pole circuit break is recommended.
12. Make sure that a differential switch with threshold of 0.03 A is fitted upstream of the system.
13. Make sure that the earthing system is perfectly constructed, and connect metal parts of the means of the closure to it.
14. The automated system is supplied with an intrinsic anti-crushing safety device consisting of a torque control. Nevertheless, its tripping threshold must be checked as specified in the Standards indicated at point 10.
15. The safety devices (EN 12978 standard) protect any danger areas against mechanical movement risks, such as crushing, dragging, and shearing.
16. Use of at least one indicator-light (e.g. FAACLIGHT 12VDC) is recommended for every system, as well as a warning sign adequately secured to the frame structure, in addition to the devices mentioned at point "15".
17. FAAC declines all liability as concerns safety and efficient operation of the automated system, if system components not produced by FAAC are used.
18. For maintenance, strictly use original parts by FAAC.
19. Do not in any way modify the components of the automated system.
20. The installer shall supply all information concerning manual operation of the system in case of an emergency, and shall hand over to the user the warnings handbook supplied with the product.
21. Do not allow children or adults to stay near the product while it is operating.
22. Keep remote controls or other pulse generators away from children, to prevent the automated system from being activated involuntarily.
23. Transit through the leaves is allowed only when the door is fully open.
24. The user must not attempt any kind of repair or direct action whatever and contact qualified personnel only.
25. Do not short-circuit the poles of the batteries and do not try to recharge the batteries with power supply units other than Master or Slave cards.
26. Do not throw exhausted batteries into containers for other waste but dispose them in the appropriate containers to enable them to be recycled.
27. **Anything not expressly specified in these instructions is not permitted.**

## **Estate Swing Summary of Functions**

The Estate Swing is only to be used for vehicular swing doors in a Class I setting.

**Class I:** A vehicular door opener (or system) intended for use in a home of one-to-four single family dwelling, or a garage or parking area associated therewith.

The FAAC Estate Swing automated system was designed and built for controlling vehicle access. Do not use for any other purpose.

The internal/external automation with articulated arms automates residential swing-leaf carriage doors with leaves of up to 8' in length. It consists of an irreversible electro-mechanical operator with guard and an articulated-arm activation system to be fitted to the door with the appropriate accessories. The irreversible system ensures the door is mechanical locked when the motor is not operating. A manual release makes it possible to move the door in the event of a power-cut or fault.

### *For Your Assistance*

**Keep this manual safely stored after installation.**

**Serial Number** \_\_\_\_\_



**Date of Purchase** \_\_\_\_\_

**Place of Purchase** \_\_\_\_\_

**Have this information on hand while handling all service and warranty issues.**



The table of contents are listed to assist you locating a desired section. We do however strongly suggest studying every page of the instruction manual before attempting installation.

## Table of Contents

	SECTION:
• <b>Review of specifications, warnings, and tools</b>	<b>1</b>
⇒ Specifications of the Estate Swing and Components	1.1
⇒ System Overview & Preliminary Checks	1.2
⇒ Tools Needed for Installation	1.3
• <b>Operator Basics</b>	<b>2</b>
⇒ Manual Operation, Restoring Automation	2.1
• <b>Installation</b>	<b>3</b>
⇒ Mounting Position	3.1
⇒ Installation of operator	3.2-.3
• <b>Pre-Programming</b>	<b>4</b>
⇒ Mounting the Control Board and Box	4.1
⇒ Removing Terminal Strips for Wiring	4.2
⇒ Installation of Limit Switches	4.3-.4
⇒ Temporary Safety Jumpers & Safety Devices	4.5
⇒ Wiring the Operator Arm(s)	4.6
⇒ Installing and Setting Transmitters and Receivers	4.7
⇒ Power	4.8 
• <b>Programming the Operator</b>	<b>5</b>
⇒ Programming Operating Parameters	5.1 
⇒ Operating Parameters Chart	5.2-.3
⇒ Programming Door Movements	5.4-.5

The table of contents are listed to assist you locating a desired section. We do however strongly suggest studying every page of the instruction manual before attempting installation.

## Table of Contents

	SECTION:
• <b>Diagnostics and Troubleshooting</b>	<b>6</b>
⇒LED Lights and Operational Displays	6.1
⇒Troubleshooting	6.2-.4 
• <b>Accessories</b>	<b>7</b>
⇒Control Board Overview	7.1-.2 
⇒Accessories	7.3



Marks pages with opener or usage warnings. Although we have marked these as very important warnings, **please read the entire manual. Every step** is important to the correct installation of your door opener.

Specifications

MODEL	Estate Swing Carriage Door Opener
Power Supply	24V AC
Rated Absorbed Power (Amperage pull on a 120V AC outlet)	3 Amp/single 5 Amp/dual
Max Torque (Nm)	200
Use frequency (cycles/hour)	> 100
Operating ambient temperature	-4 to 131 Deg F
Gearmotor weight (lbs)	25
Protection class	IP44
Door leaf max length (ft.)	Up to 8
Door leaf max weight (lbs.)	Up to 800
Operator overall dimensions LxHxD(in.)	See below
Angular velocity	8 Degrees / Second

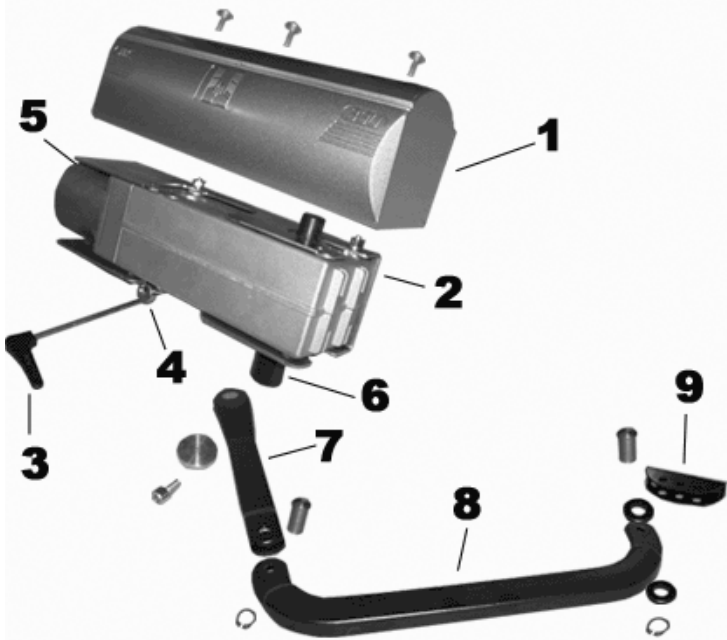

- 1) Guard
- 2) Operator securing base-plate
- 3) Release wrench
- 4) Release
- 5) Gearmotor
- 6) Transmission shaft
- 7) Straight lever of articulating arm
- 8) Curved lever of articulating arm
- 9) Front coupling

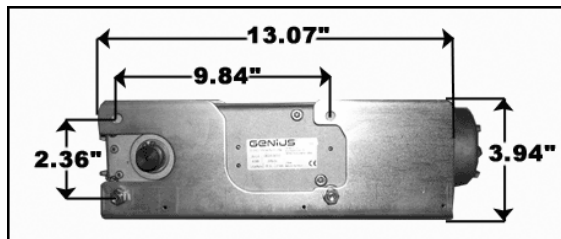
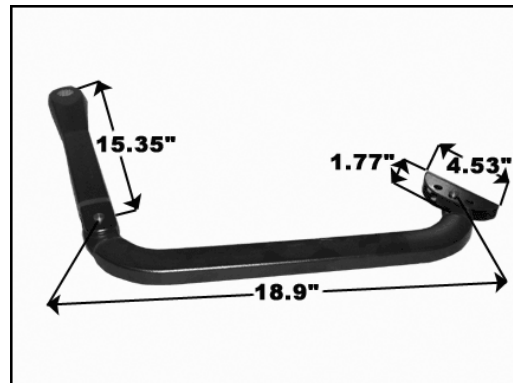
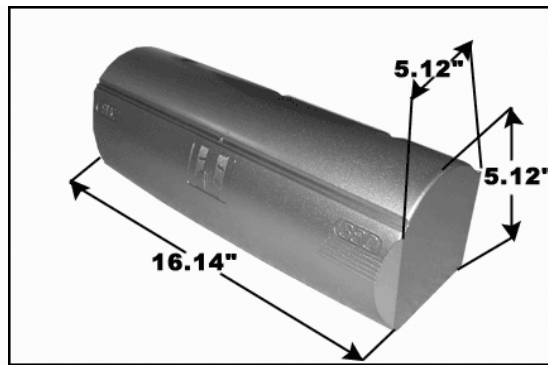

**Estate Swing Parts List**

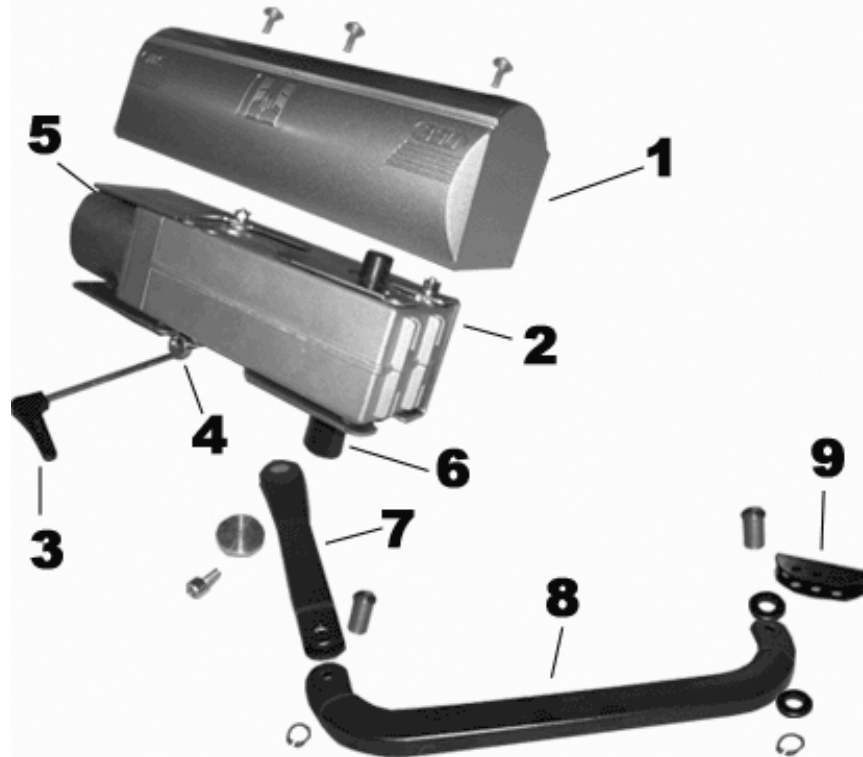

**Master Operator**

1. Housing Cover
2. Wall Mounting Plate
3. Manual Release Chain Pull (not fully pictured)
4. Manual Release
5. 24VDC Motor
6. Transmission Shaft
7. Straight lever of articulating arm
8. Curved lever of articulating arm
9. Door Mounting Bracket

**Slave Operator**

1. Housing Cover
2. Wall Mounting Plate
3. Manual Release Key
4. Manual Release
5. 24VDC Motor
6. Transmission Shaft
7. Straight lever of articulating arm
8. Curved lever of articulating arm
9. Door Mounting Bracket

**Not Pictured**

1. Manual release chain
2. Open position limit cams and switches

**Tools Needed**



- Power Drill and appropriately sized bits.
- Crescent Wrench
- Flat Head Screwdriver
- Nuts, Bolts, Anchors and Washers (see below)
- C-Ring Pliers

- Phillips Head Screwdriver
- Tape Measure
- Level
- Wire Strippers
- C-clamps
- Carpenters Clamps

**Diagnostics**

**Other items that may be needed prior to commencing installation.**

- **16, 14 or 12 gauge, 2 conductor stranded low voltage wire will be required to run power to your operator.** Length is determined by distance between transformer power supply and the control box.
- A voltage meter and digital camera may be necessary to run diagnostic checks.
- **4 - 3/8" fasteners will be needed to connect the Base Plate to the wall.** Length and style will be determined by what is needed for a secure anchor for your material door.
- **2 - 5/16" fasteners will be needed to connect the Door Mounting Bracket to the door.** Length and style will be determined by what is needed for a secure anchor for your material door.
- Hardware to attach the control box to a wall.

## **Emergency & Operational Manual Operation Mode**

**For one door**, the door that can open independently from the other door (if there is an overlap), **you will insert in the manual release the provided emergency manual release lever with pull chain and leave in place for emergency release.**

**In emergencies pull down on the chain and this will release the door.**

Test periodically for correct placement and function. Resetting lock mode same as below.

Manual operation mode will be necessary to learn from installation and programming. It is also useful for emergency situations where as using the motor is not an option from operation the doors.

Fit the supplied Allen wrench and turn it by approximately a half a turn until it stops. Turn it in the direction that is dictated below.

### **For left-hand side:**

Turn counterclockwise to lock, clockwise to unlock.

### **For right-hand side:**

Turn counterclockwise to unlock, clockwise to lock.

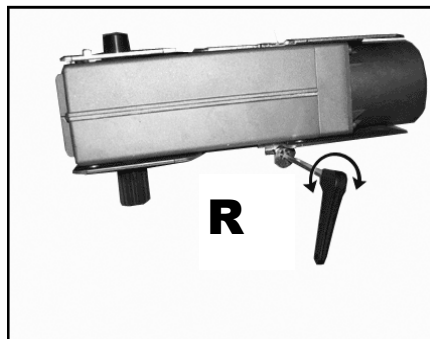
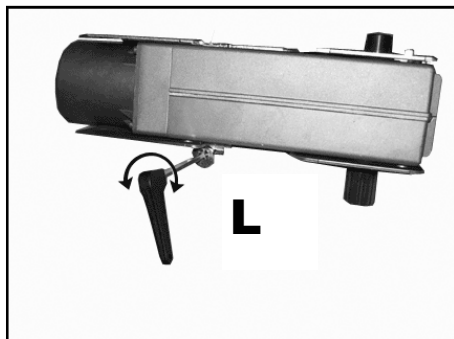

## **Restoring Standard Operation**

**To avoid an involuntary pulse activating the doors during the maneuver, before re-locking the operator, switch off all power.**

Fit the supplied Allen wrench and turn it by approximately a half a turn until it stops. Turn it in the direction that is dictated above.

## IMPORTANT: Determining Correct Position

This operator is intended to be on the inside of the garage and push the carriage doors out towards the driveway.

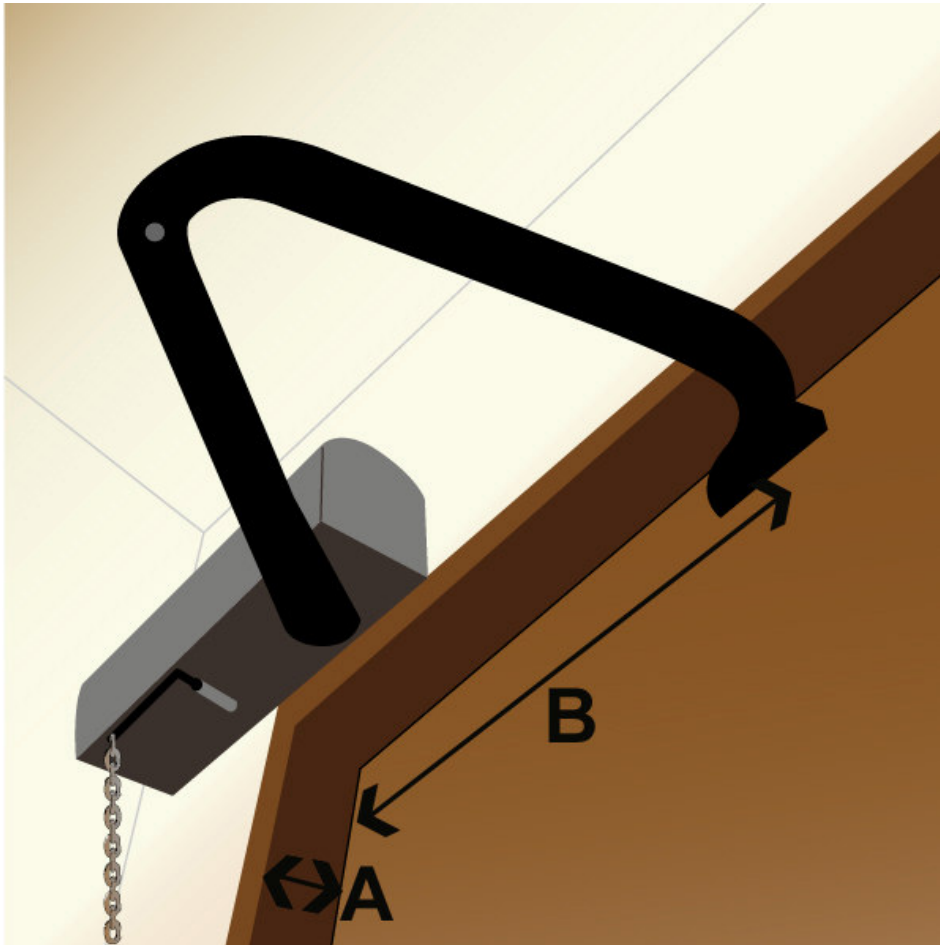

Position the mounting plate above the door frame with the release just inside the frame the door frame. The drive shaft (piece that comes down from the motor that makes the arm pivot) should be positioned inside the door frame.

**A = No minimum, but do not exceed 12"**

**B = 29" - A measurement = distance from hinges of door to center of door bracket. Example: if A is 8" then B (29-8) is 21"**

## Installation of Operator

The operator base plate and articulated arm are designed either for right-handed or left-handed installation. There is no pre-determined designation.

1. Begin with your gear motor in the base plate. Hold the base and motor against the Wall above the door and find the proper position for your operator (from previous page). Mark the outline of the base plate with the operator in the correct position. Then remove the motor from the base plate.
2. Secure the base plate to the wall using screws and a proper anchoring system for your type of wall or frame material.

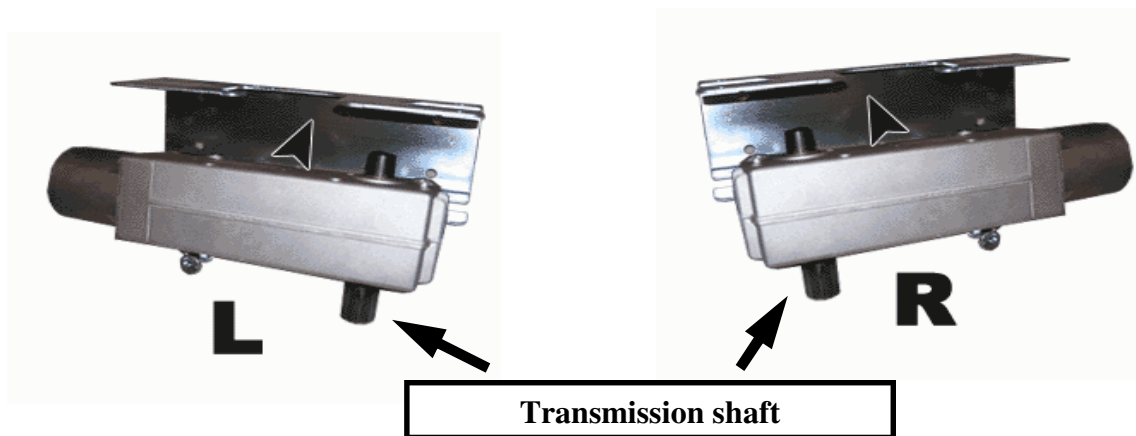

3. Fit the gear motor back onto the base plate and secure it with two screws, nuts and washers.

**Important: The transmission shaft must always face downward.**

Continued on next page.

4. Assemble the articulated arm and front coupling as shown below. Left assembly connects the same way as the right only with the straight arm and door bracket on opposite sides as in the smaller picture below.

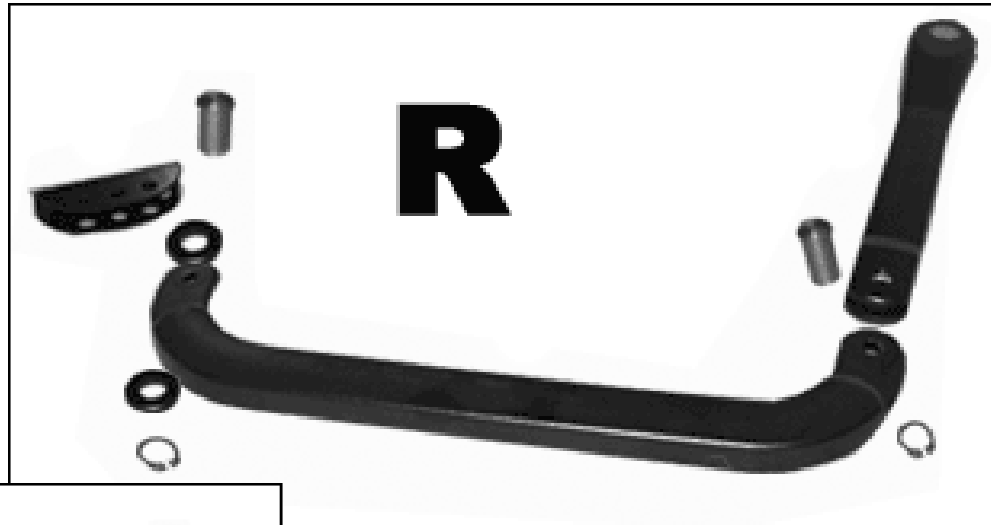

5. Fit the straight lever of the articulated arm on the transmission shaft and tighten it using the supplied screw and washer.
6. Manually release the operator (From section 2)
7. Find securing point **B** from the mounting set back determined from the previous page. Verify the arm is level, then temporarily remove the coupling from the arm in order to attach the door mounting bracket. Attach the door mounting bracket to the door using nuts, carriage bolts and washers.
8. Reconnect the coupling from the door mounting bracket to the arm.



**Do not place the cover on yet. Wait until later in the installation process when you have your limit switches installed and wired. Then attach the cover.**

9. Relock the operator.

## Mounting the Control Board and Box

1. Position your control box on the post of the door or a near by fence. Remove the rubber covers on the back of the box to reveal the holes marked 1 in the picture. Use these holes to mount the box and then put the rubber covers over the screw heads to prevent water leakage. *For a dual operator set-up, the control box will be on the same side of the driveway as the master control arm.*
2. To mount the control board, first mount the control board stand in the center of the box using screw holes marked 2 in the picture.
3. Attach the control board to the control board stand using the holes marked 3 in the picture.

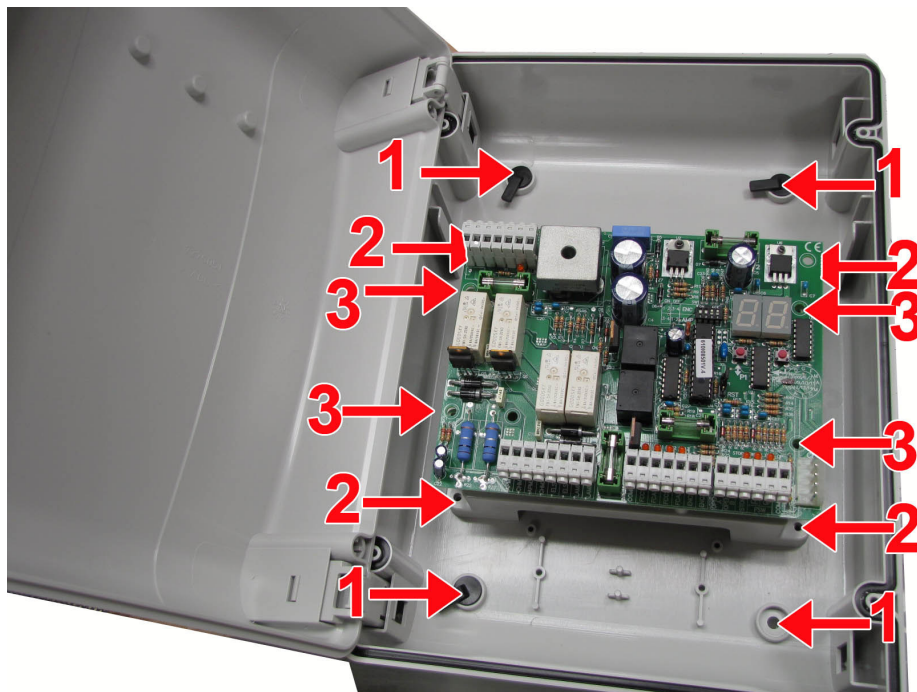

Back up batteries are positioned below the control board.





## Installation of Limit Switches

The closed position is controlled by the door reaching the door frame. The open is controlled by limit switches. These must be installed before learning.

For the carriage door usage of this motor you must be on operating parameter:

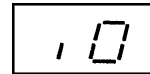

### Open Limit switches

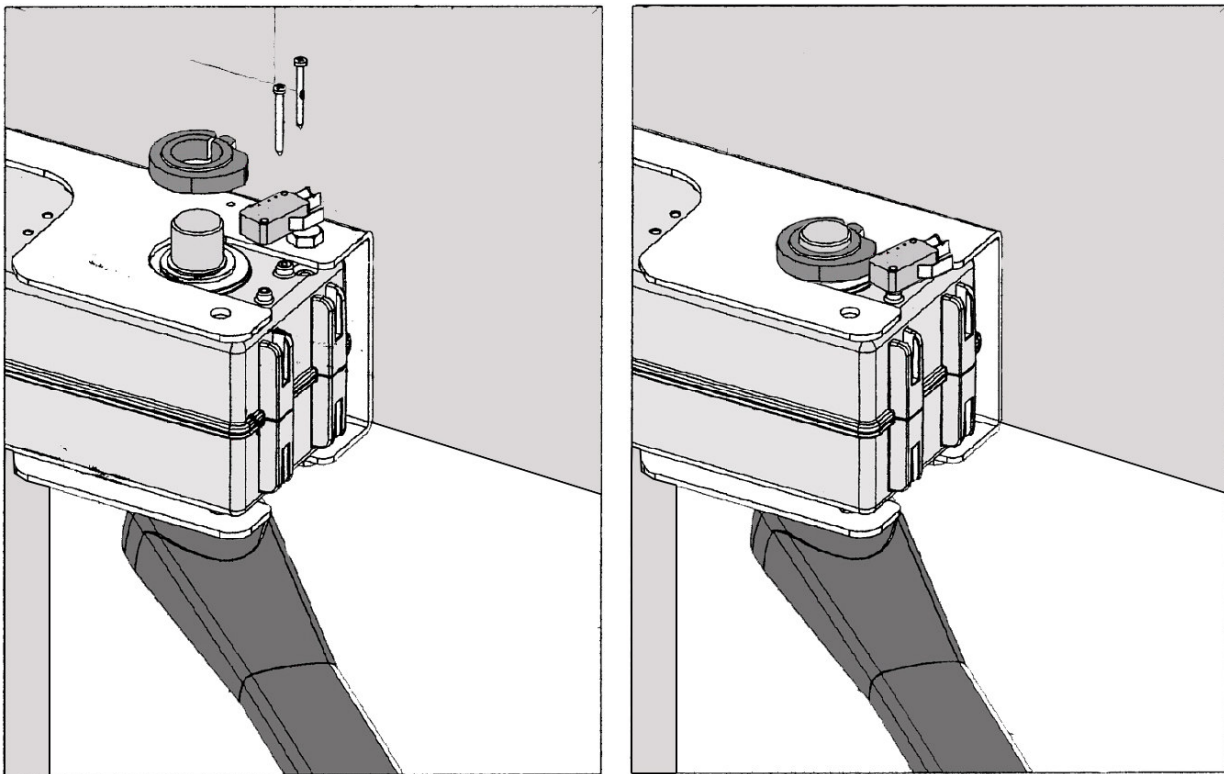

#### Mounting the limit switches

Slide the limit rings on the top side of the transmission shaft. Line up the holes on the limit switches with the holes on the top of the operator. Manually release the arm.

Move the door into the full open position. Move the top ring until it is pushing the switch on the limit switch in. Tighten the screw on the top ring to secure it in place.

Example of how to tighten the limit ring.

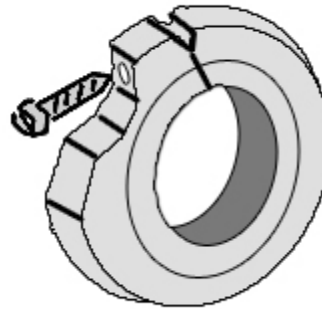

### Wiring the Limit Switches

On the limit switch:

- 1 is Common
- 2 is N/C Limit Connection
- 4 is not used

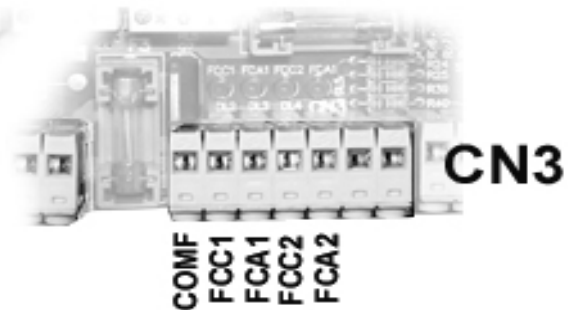

Terminal Block CN3	
COMF	Common from all limit switches
FCC1	Jump to COMF
FCA1	N/C Limit Connection <i>Open Door Limit Switch on Master</i>
FCC2	Jump to COMF
FCA2	N/C Limit Connection <i>Open Door Limit Switch on Slave</i>

## Temporary Safety Jumpers

For the highest level of safety, the Estate Swing systems are set up with Normally Closed safety terminals. This means that in order for the door opener to move these terminals must be closed either through a safety device (recommended) or with jumpers. Temporary safety jumpers are provided in the control box hardware bag for jumping these terminals to common (COM) during the set-up process.

*It is recommended not to use any accessories until setup and programming are complete.*

**NOTE: If not using safety devices the temporary safety jumper must remain in. In order for the door operator to move, all three safety terminal lights (STOP, FSW CL, FSW OP) must be lit.**

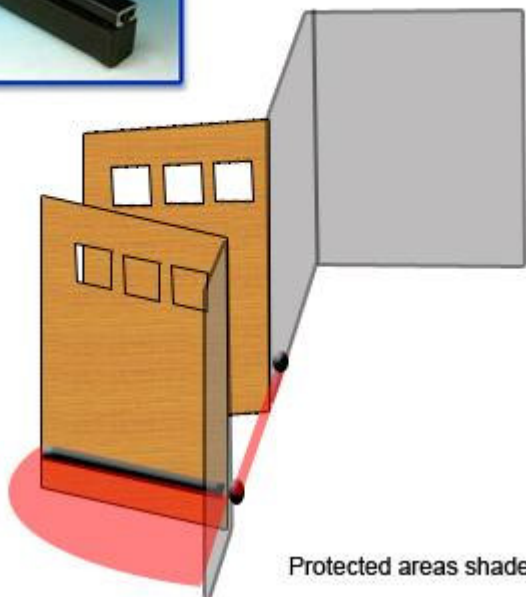
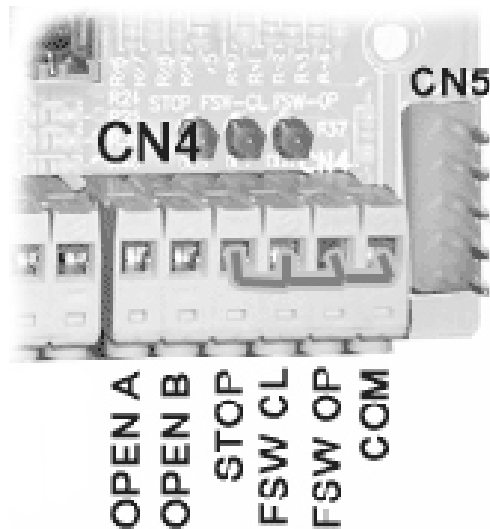

Protected areas shaded red

To the left is our recommended safety set up. It consists of safety edges mounted on the door on the outside to react rapidly to impact and photo beams at the base of the door to halt movement of the doors with obstruction.

## Wiring The Operator Arm(s)

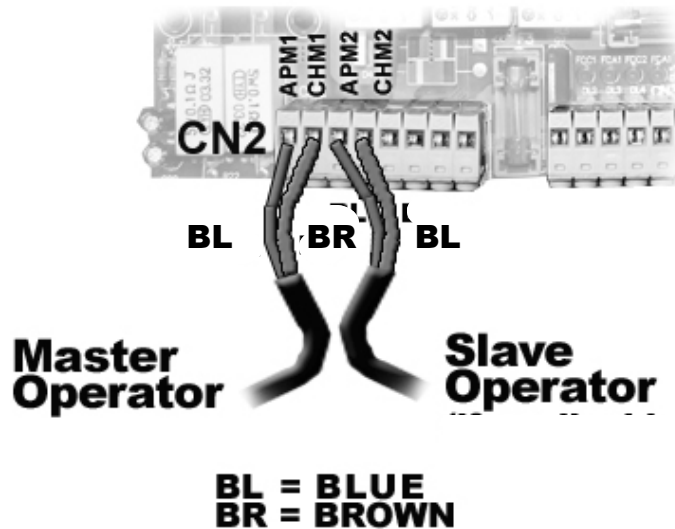

**For the Master Operator:** In terminal block CN2 insert the **BLUE** wire in APM1 and **BROWN** wire in CHM1.

**For the Slave Operator :** In terminal block CN2 insert the **BROWN** wire in APM2 and **BLUE** wire in CHM2.

\*During the learning process, if the door begins to move in the wrong direction. Stop the door operator by removing power or tripping RESET switch. Then swap the brown and blue wires, this will make the operator start in the right direction when you restart the run time learning procedure.

## Installing and Setting Transmitters and Receivers

### Installing the Receiver

- 1) Locate the 5 Silver Pins in the lower right hand corner of the Estate Swing board.
- 2) Locate the **white** connector on the receiver.
- 3) Push the **white** connector from the receiver on the 5 pins on your control board with the dip switches of the receiver board facing away from the Estate Swing board.



### Setting the Dip Switches

- 1) Set the dip switches 1-9 on the receiver by switching them in the up or down position.  
*Record this dip switch combination*
- 2) Slide off the battery cover of the transmitter (*located at the bottom front cover*)
- 3) Set the dip switches in the transmitter to the same settings as the dip switches on the receiver.
- 4) Repeat this for all of the transmitters.

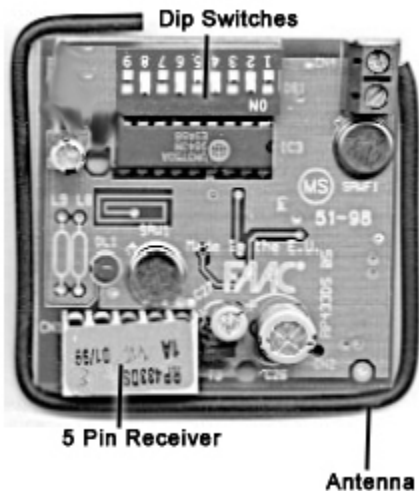

Dip switches are located under the battery lid.

## Power

1. The Estate Swing Heavy Duty Carriage Door Opener comes with 1) 24V transformer. The transformer supplied has 2 screw terminals to connect to. You may locate the transformer up to **100'** away from the control board using **16 Gauge, 2 Conductor Stranded Direct Burial Wire** below.
2. Insert the two wires from the transformer into the two VAC terminals on the control board (CN1). The wires are not polarized, there is no positive or negative. **Do not splice the power cable wire.**



**Never run 110VAC power directly to the Estate Swing. This will destroy the Estate Swing control board.**

*Never connect the power wire with the transformer plugged in. Contact between the two lead wires, even for a second, will destroy the transformer.*

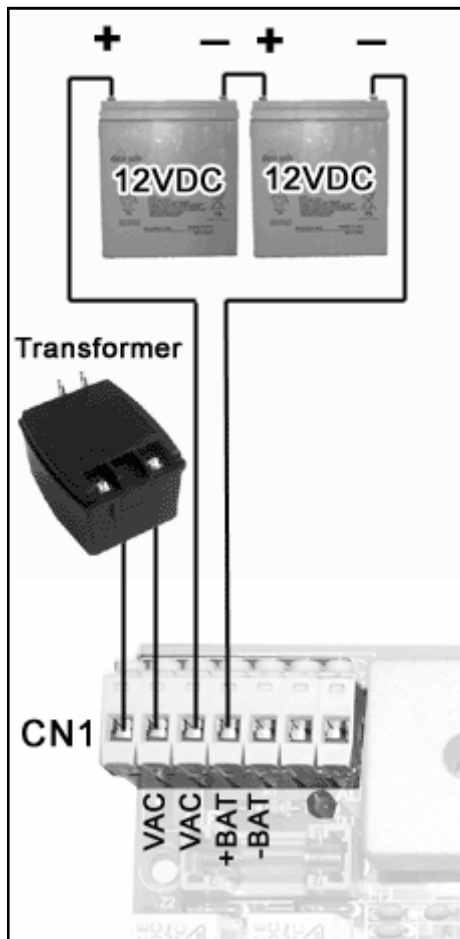

3. Plug the **transformer** into a 110 V AC outlet.
4. The transformer is not weather proof and must be kept in a covered area. *Plug covers are available from your dealer, contact 1-800-640-GATE for a dealer in your area.*
5. Two 12V DC batteries may be run in series as backup to the 24V transformer power. Running two 12V batteries (Max 5 a/h per battery) in series creates a 24V system, *you cannot run them in parallel* (see diagram to the left)
6. The power light located below the +24V and -24V output terminals will be on if the power is connected properly. If the light is off then power through the transformer is not functioning properly and either the unit has no power or is on battery backup. *The light stays off during battery backup.*

## Setting Operating Parameters



Complete this step prior to programming the door run time. This will dictate how your door will react during programming and normal operation.

It is not necessary to reset these if power is removed or if reset is tripped, they will stay set.

### Important Dip Switch Setting

Verify the 4 dipswitches to the left of the display LED are as follows:



1. DOWN
2. DOWN
3. UP
4. UP

### Entering programming mode

1. Make the necessary power connections and check the LED lights to be sure the appropriate lights are lit.
2. The display should show --
3. Press and hold down **P2** until the display shows parameter A with the corresponding number that is currently default or previously programmed.
4. Press **P1** to change the number variable of the parameter, **USE THE CHART ON THE NEXT PAGE AS A GUIDE.**
5. To move to the next parameter, Press **P2**.
6. When 60 seconds have elapsed without any button being pressed the control unit automatically exits the programming mode. To exit manually, Press **P2** to scroll through all the parameters until the display shows --

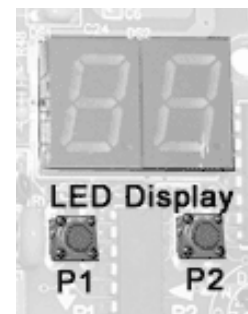

## Operating Parameters Chart

<u>A 1</u>	Minimum Force	<b>FORCE</b>	This parameter adjusts the sensitivity of the electronic clutch system. The electronic clutch system controls the anti-crushing auto-reverse feature when a door in motion makes contact with an obstacle.
<u>A 2</u>	Medium-low Force		
<u>A 3</u>	Medium-high Force		
<u>A 4</u>	High Force		
<u>b 1</u>	1.5 Second Offset	<b>DELAY</b>	This determines how long the second leaf will pause before moving to allow the first leaf to separate and avoid obstructing on the other leaf.
<u>b 2</u>	3 Second Offset		
<u>b 3</u>	6 Second Offset		
<u>b 4</u>	10 Second Offset		
<u>c 0</u>	Disabled	<b>AUTO- RECLOSE</b>	<b>c0 recommended for safety.</b> This parameter turns auto-close on or off. The pause time for the auto-close is set during movement programming.
<u>c 1</u>	Enabled		
<u>d 0</u>	Opens/Closes/Opens...	<b>OPEN A</b>	This parameter determines what an OPEN A terminal command will result in. <b>d1 is recommended for safety.</b>
<u>d 1</u>	Opens/Stops/Closes/Stops...		
<u>E 0</u>	Disabled	<b>CONDO</b>	<b>E0 recommended for safety.</b> This parameter is for use with multiple door users. If enabled, when the door is opening it can not be reversed by another open signal.
<u>E 1</u>	Enabled		
<u>F 0</u>	Disabled	<b>OVER- PUSH</b>	<b>F0 required for carriage doors.</b>
<u>F 1</u>	Enabled		
<u>G 0</u>	Flashing Lamp	<b>LAMP</b>	This parameter is to determine between a flashing or steady lamp. If not using a lamp the setting will not affect your door.
<u>G 1</u>	90 Second Courtesy Light		

Continued on following page.

<b>H 0</b>	20% of total arch	<b>SOFT START/ STOP</b>	This parameter determines when the door will begin to slow down near the end of opening and closing cycle.
<b>H 1</b>	10% of total arch		
<b>1 0</b>	Low	<b>SOFT SPEED</b>	Parameter must be on 0.
<b>1 1</b>	High		
<b>L 0</b>	No Limit Switch	<b>LIMIT SWITCH</b>	Parameter must be on L0
<b>L 1</b>	Limit Switch		
<b>n 1</b>	Single Leaf Door	<b>SINGLE OR DUAL</b>	For carriage doors set to n2
<b>n 2</b>	Dual Leaf Door		



After programming your last parameter you may now move on to programming your door run time. Press P2 one more time to exit this mode. Door movement instructions begin on the next page.

## Programming Door Run Times

In this stage, your control board will memorize where your limits are (identified by limit switches, positive stops or both) in both opening and closing phases. Also if the auto-close feature is activated it will learn the user specified pause time.

**FOR SAFETY PURPOSES—your opener will not run until this step is completed**

1. Release the operator gears using the manual release process. Once released, manually move the doors half way between the open and close stop points.
2. Relock the operator gears at the half way point through its cycle. Verify your operator control board is showing **--** on the LED display.
3. Press and hold down **P2** until the LED display shows the A parameter and the relevant number appear in the LED display.
4. Give an **OPEN A** command. This can be done with any opening device (keypad, push button, etc...) wired into OPEN A and COM or using the transmitter. You can also briefly (one second or less) jump OPEN A and COM with a wire. This will begin your doors in the **CLOSING DIRECTION** and the LED display will read **"Pr"**.



**Both doors are programmed simultaneously. Both leafs will move together through the same programming sequence. There is a slight starting delay on the slave side.**

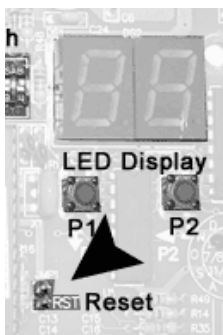

**IMPORTANT:** If the doors begin to open rather than close, the doors must be stopped with a reset pulse.

You can either:

Touch the TWO pins of the JMP "RESET" using a screwdriver **OR**  
Disconnect all power (transformer and backup battery)

Then switch the wires leading into APM1-CHM1 for master and APM2-CHM2 for slave and then begin programming again.

## Estate Swing

5. When the closing stop point or limit switch is reached, the motor pauses for approximately 2 seconds, and then restarts with a total opening maneuver to the opening stop point or limit switch.

6. When the full open stop or limit switch is reached the doors will stop.

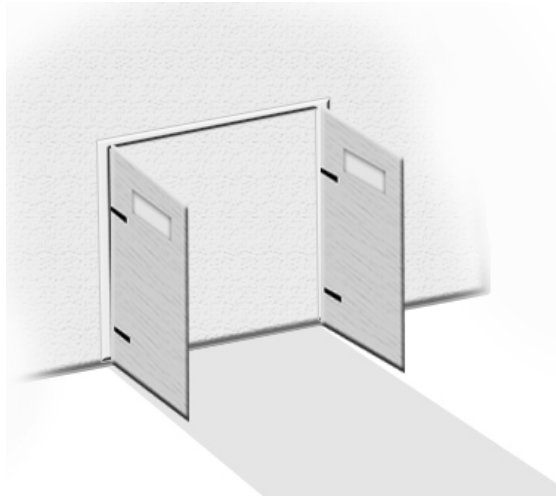

7. Once they stop in the open position signal your opener using an OPEN A contact or transmitter signal to close the doors. The doors will then return to closed and programming will be complete.



**If you decide to use auto-reclose (not recommended)** after the doors reach the full open wait for the amount of time you would like your doors to pause for during normal operation before automatically re-closing and then complete step 7.

## LED Lights & Operational Displays



**Control Board LED Lights** - The control board LED lights are located above their respective terminals that they represent. (With exception of ALIM, power supply light, which is located below the power terminals in the upper left corner.) The LED lights are a quick way of verifying necessary connections are made. Below is a chart of their interpretations.

LED	ON	OFF
ALIM	Powers supply by transformer	Power supply by battery or no power
FCC 1	Motor 1 closing limit switch - not tripped	Motor 1 closing limit switch - tripped
FCA 1	Motor 1 opening limit switch - not tripped	Motor 1 opening limit switch - tripped
FCC 2	Motor 2 closing limit switch - not tripped	Motor 2 closing limit switch - tripped
FCA2	Motor 2 opening limit switch - not tripped	Motor 2 opening limit switch - tripped
STOP	Stop command - not activated	Stop command - activated
FSW CL	Closing safety device - not tripped	Closing safety device - tripped
FSW OP	Opening safety device - not tripped	Opening safety device - tripped

**If not using safety devices , you must jump STOP, FSW CL and FSW OP to COM in order for the door opener to function.**

**Standard Operation Display** - This is when the door opener is not in parameter setting mode or programming mode. LED displays DS1 and DS2 will show the following:

### Door Status

- — Door At Rest in Closed Position
-  Door Opening or Door Open when Auto Close is OFF
-  Door open in pause status  
(Only with automatic re-close enabled - Parameter c)
-  Door Closing

## **Troubleshooting**

### **If the door opener will not move.**

Be sure you have gone through programming. Without programming no power is ever sent to the operator arms.

Check wiring connections.

Check to be sure jumpers are in place between STOP, FSW OP, FSW CL to COM on terminal block CN4.

If not using limit switches, be sure jumpers are in place between FCC1, FCA1, FCC2, FCA2 to COMF on terminal block CN3.

Be sure the arms are locked out of manual operation.

Check all fuses, the fuses protect as follows but all are required for the arms to move:

F1: 10A – Power Supply, 24VAC

F2: 630 mA – Power supply to accessories and battery charger

F3: 630 mA – Flashing lamp output

F4: 3.15A – Electric Lock Output

### **If the door opener move a few inches or feet and stops or reverses directions.**

Check dip switches to the left of the LED display. It should be 1:OFF, 2:OFF, 3:ON, 4:On. If the dip switches are wrong, you **must** turn all power off before changing the dipswitches and then turn power back on for the settings to take effect.

Increase the force setting to the highest force. The force setting is the A parameter, move the A parameter to 4. If the door moves fully after doing so you may then work your way down force settings to the lowest force setting that the door still moves correctly under.

Check the setback. The setback of the operator is important to correct operation due to leverage the arm will have on the door.

If using limit switches, check limit switch placement and wiring. You can tell if a limit switch has been triggered by watching to see if one of the lights above FCC1, FCA1, FCC2, FCA2 go unlit. Whichever limit light is unlit is engaged.

*Continued on next page.*

### **If fuse the F2 fuse blows or continues to blow.**

Check all wiring to both the backup batteries and to all accessories run off of the 24+,- terminals on terminal block CN1. Check for the following:

- The batteries are run in **series** not parallel. If they are run in parallel the batteries will become overcharged and be destroyed, which will then create a short and continually blow the F2 fuse.
- The accessories going into 24V+, - must have the correct polarity.
- The accessories going into 24V+, - cannot exceed a combined power draw of more than 500 mA.

Check the battery voltage, if the battery voltage is very low you may have dead cells in the battery causing an overdraw of current and blowing the fuse. Replace the batteries.

### **If the door reaches it's closed position during the learning process but does not re-open.**

Touch the reset pins (RST) to reset the system. Change the i parameter to 0. Restart the learning process.

Contact Estate Swing for alternate power supply to correct a lack of correct voltage and/or amperage outputs under load.

### **The door does not reach the desired stop points.**

Closed position:

- Be sure the arm can go full expected range. Manually release the arms and move the doors by hand to possible range. Do not let the arm reach its physical limitations before the stops during normal operation.
- If arms can't extend full expected range, check the setback.
- If the opener arm has the physical possibility of opening yet still stops, increase the force setting to the highest force. The force setting is the A parameter, move the A parameter to 4. If the door moves fully after doing so you may then work your way down force settings to the lowest force setting that the door still moves correctly under. The ending positions are where the most stress is put on the arm and the leverage is the lowest.

Open position:

- Check limit switch placement and wiring. You can tell if a limit switch has been triggered by watching to see if one of the lights above FCC1, FCA1, FCC2, FCA2 go unlit. Which ever limit light is unlit is engaged.
- If limit switches are to the furthest points possible on both the closed and open positions, check the setback.
- If the opener arm has the physical possibility of opening yet still stops, increase the force setting to the highest force. The force setting is the A parameter, move the A parameter to 4. If the door moves fully after doing so you may then work your way down force settings to the lowest force setting that the door still moves correctly under. The ending positions are where the most stress is put on the arm and the leverage is the lowest.



**If you call in for technical support or warranty support: before any control board or motor will be permitted to be sent in for testing or warranty you will be required to e-mail digital photos to the technician.**

This is done in your best interest to save unnecessary shipping expenses and time lost. Many times we can come up with solutions to issues by seeing pictures that relay information that is impossible to relay through a phone conversation.

*Below are examples of control board pictures and motor pictures that we will be looking for:*

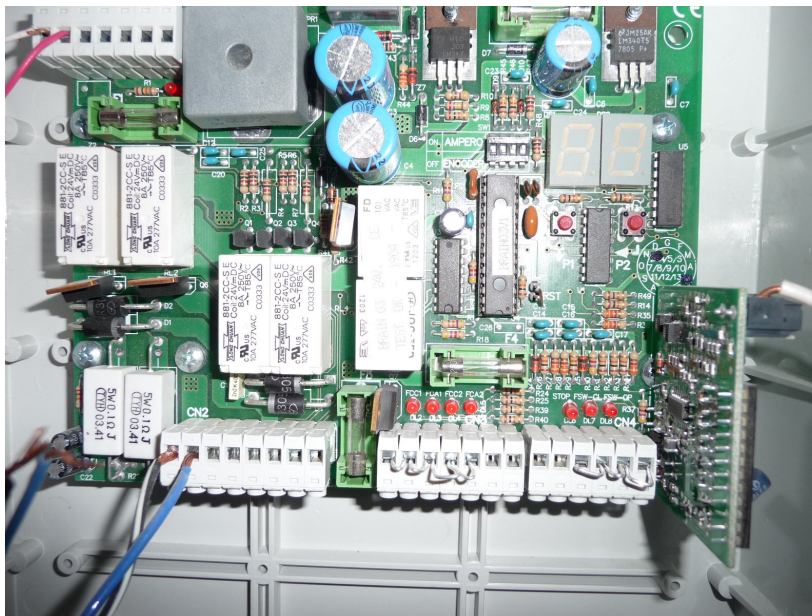

## Control Board Overview



**Caution!** Do not run 110V AC power direct to the board. This will cause permanent damage to both boards and void your warrantee. **Caution!**

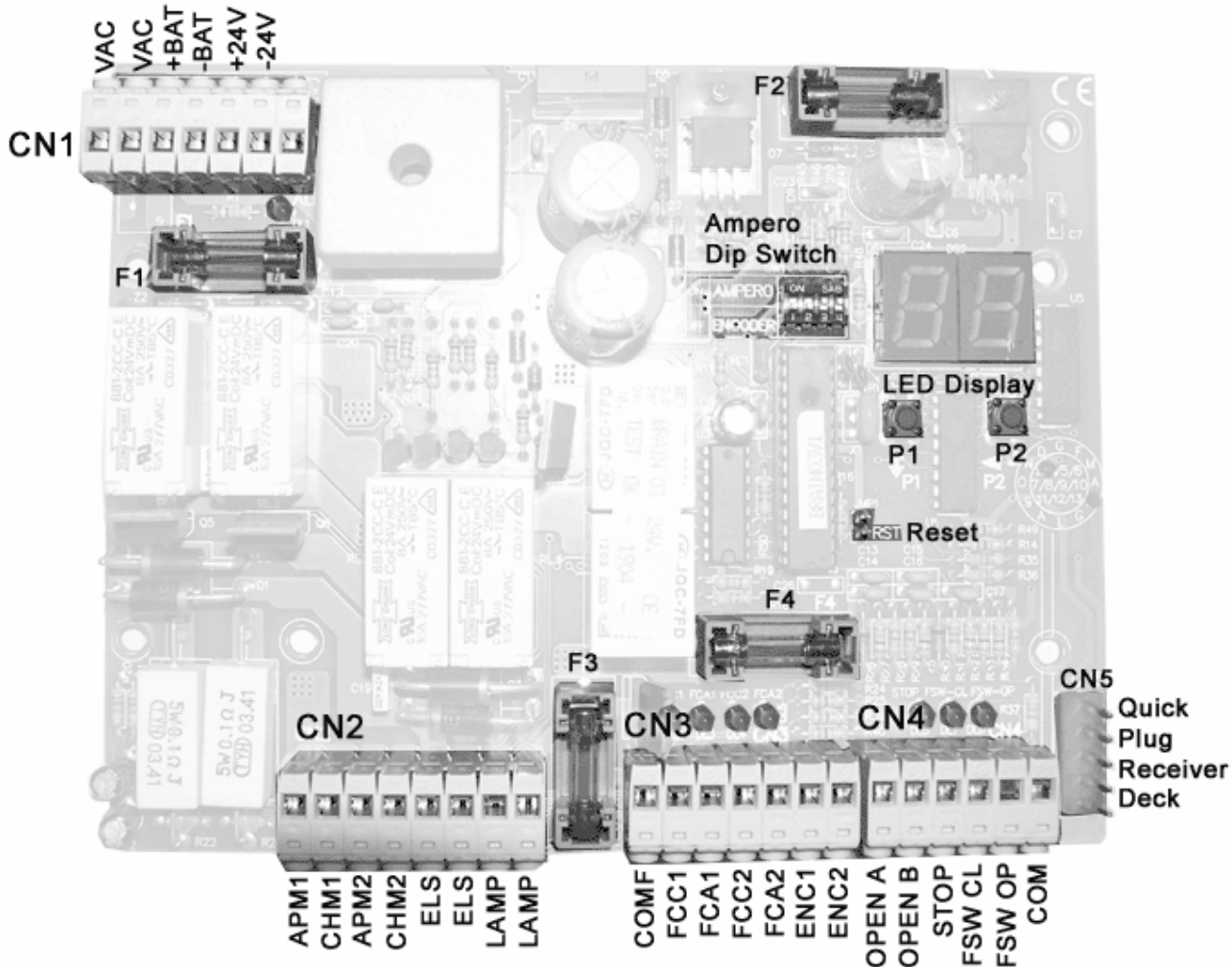

### CN1 - Upper left hand corner of board, used for power and back up power.

- **VAC - terminals.** The input terminals for the supplied 24V transformer. Polarity is not an issue for this terminal.
- **+BAT, -BAT - terminals.** Input terminals for the optional backup batteries. The battery power coming in must be 24V DC. This can be achieved by running two 12V batteries (Max 5 a/h per battery) in series. During normal operation, the unit keeps the batteries charged and the batteries begin operating the unit if no power is being supplied through terminals VAC. Observe polarity on these terminals.
- **+24, -24 - terminals.** Accessories needing constant 24V power should be attached to these terminals following the correct polarity. (Example: Alternate receiver, exit wand)

Continued on following page.

**CN2 - Located on the lower left side of the board, these terminals are outputs for the operator arm(s), door locks (optional), and lamps (optional).**

- **APM1, CHM1 - terminals.** Connect the arm that must move first, for single operations these terminals are the output for controlling the operator arm.
- **APM2, CHM2 - terminals.** Connect the arm that is to move second to these terminals. For single operations nothing should be connected to these terminals.
- **ELS - terminals.** Brief 12V output at beginning of operation cycle, meant for release an electric lock.
- **LAMP - terminals.** Both a flashing lamp and a courtesy lamp can be connected to these terminals with a power supply of 24V DC and a max output of 15 W. to change between flashing lamps and courtesy lamps, select parameter “G”.

**CN3 - Located on the center bottom of the board, these terminals are for limit switches.**

- **COMF - Common terminal** to make the needed normally closed connections for the limit switches.
- **FCC1 - This terminal must be jumped with COMF) Master Closed Limit Switch**
- **FCA1 - Normally closed contact.** This terminal is connected with the COMF through the limit switch. When tripped (connection opened) it stops the motion of the first operator. *(If not being used, this terminal must be jumped with COMF)* **Master Open Limit Switch**
- **FCC2 - This terminal must be jumped with COMF) Slave Closed Limit Switch**
- **FCA2 - Normally closed contact.** This terminal is connected with the COMF through the limit switch. When tripped (connection opened) it stops the motion of the second operator. *(If not being used, this terminal must be jumped with COMF)* **Slave Open Limit Switch**
- **ENC1, ENC2 - terminals. NOT USED**

**CN4 - Located on the bottom right of the board, these terminals are for accessories and safety devices.**

- **OPEN A - terminal.** This is the most common terminal for accessories. Accessories utilizing a normally open contact to set the door in motion will be attached to this terminal and the COM terminal (common or also know as ground).
- **OPEN B - terminal.** This terminal is for opening the first leaf only in dual door operations. It is a normally open contact that must be used in conjunction with the COM terminal.
- **STOP - terminal.** This is a normally closed terminal that is used for door motion stopping emergency commands. **If a safety device is not being used in this terminal the operator must have a jumper ran from this terminal to the COM terminal in order to operate.**
- **FSW CL, FSW OP - terminals.** These normally closed terminals are for safety devices during the closing (CL) and opening (OP) cycles of the door. **If a safety device is not being used in this terminal the operator must have a jumper ran from this terminal to the COM terminal in order to operate.**
- **COM - terminal.** This is a common, or sometimes referred to as ground, terminal. It is used in conjunction will **ALL** accessories and safety devices.

## **Installing Accessories**

Accessory manuals for most make and model accessories can be found on the web at:

[www.EstateSwing.com/accessories](http://www.EstateSwing.com/accessories)

The accessory manuals you have or find at the above address may be written to coincide with that manufacturer's model of door opener. To determine correct terminals on your Estate Swing operator, use the accessory terminal section of your Estate Swing manual. The following are some common terms and abbreviations found in manuals:

**Normally Open** – abbr. N/O – Indicates a circuit that is left open during normal operation of the door operator. When a device closes this circuit it signals the operator to perform a function. This circuit is the main circuit for entry devices. (i.e. keypads, exit wands, push buttons, etc.)

**Normally Closed** – abbr. N/C – Indicates that in order for the door opener to be active this circuit must be closed. When a device opens this circuit it stops the motion of the door operator. This circuit is the main circuit for safety devices. (i.e. photo eyes, safety loops, etc.)

**Common** – abbr. COM – This is the matching terminal for both Normally Open and Normally Closed circuits to be connected to. Accessory wiring that begins in a N/O or N/C terminal must have a wire that ends in a Common terminal.

**Ground** – abbr. GND or GRD – Ground is sometimes also known as negative. Common terminals are the same as Ground terminals. Ground can also be the negative spade of the battery if it is being used in association with positive voltage.

If a device has both a N/O and a N/C wire, both are never used at the same time. Some devices can be used as either an opening device or a safety device (i.e. safety edge, photo eye, etc.) If being used as an opening device use the N/O and if being used as a safety device use the N/C terminals.